



- ▶ Meet the Local Heroes Full Coverage Inside
- ▶ New Label Reporting Form
- ▶ 2013 Hall of Fame Call for Nominations
- ▶ Technician's Corner Industry Advisor + more!

▶▶▶ THE NMEDA NEWSLETTER



Congratulations to the Local Heroes!



NationalMobilityAwarenessMonth.com

NMEDA
National Mobility Equipment Dealers Association



Valet™ *Signature Seating*

The New Valet™ Plus

A luxury seat that combines elegance with marvelous functionality, the Valet Plus represents the reward you deserve. Individually programmed at installation to ensure the best fit and function, the Valet Plus features power forward/backward seat adjustment with full seat recline. With an impressive array of colors, and new Metro Tech fabric and Ultraleather™ Plus materials – it feels like the seat has been tailored just for you!

Let the Valet Show You to Your Seat!



1-800-462-0664 • www.bruno.com

code: CIRCUIT0512



President

Sam Cook

CEO

Dave Hubbard

Layout, Editor & Creative Director

Jenna DeTrapani

Contributing Writers

- Sam Cook
- Dave Hubbard
- David Hutchison
- Richard May
- Ron Mohr
- Dan Drury
- Jacques Bolduc, P. Eng.
- Pete Lucas

The **Circuit Breaker** is published quarterly by the National Mobility Equipment Dealers Association.

Office located at 3327 W. Bearss Avenue, Tampa, FL 33618. For business office, advertising and subscriptions:

Tel: 813.264.2697
 Toll Free: 800.833.0427
 Fax: 813.962.8970
 www.nmeda.com
 info@nmeda.org

Subscription rates for the U.S.A and Canada: \$16.50/4 issues. Back issues are available by calling the NMEDA office.

All rights are reserved under copyright laws © 2012. Media note: Permission is granted to quote or reprint from this publication. Please credit the Circuit Breaker.

The articles published in the Circuit Breaker reflect the opinions of their authors, not NMEDA. As such, NMEDA neither takes a position on nor assumes responsibility for the accuracy of the information or statements contained therein.

SUMMER 2012 ►►► VOLUME 19, ISSUE 2

CONTENTS

FEATURES

- 20 National Mobility Awareness Month**
 One World. One Cause.
 Local Heroes Announced
- 24 NMEDA News Brief**
 - 3rd Quarter Finance Report
 - NMEDA Hall of Fame 2013:
 Call for Nominations
- 29 Along the Newswire**
 - VMI Online Wheelchair Lift
 Application Guide
- 37 Your Training Source**
 - Another Successful CAMS-HP
 - Manufacturer Service
 Schools Coming Soon
 - Manufacturer Service School
 Presenter Registration
- 40 Industry Advisor**
 - New Label Reporting Form
 - Proposed Changes to
 FMVSS 210 Test Method
 - Proposed Changes to
 Accelerator Control Systems

COLUMNS

- 6 President's Letter**
 By Sam Cook
- 18 CEO's Report**
 By Dave Hubbard
- 36 Technician's Corner**
 By Ray Morton
- 46 Canada Regional Report**
 By David Hutchison
- 48 Regional Reports**
 By Your Regional Reps

ALSO

- 4 2012 Board of Directors**
- 10 List of NMEDA Dealers**
- 28 Hall of Fame Nomination Form**
- 30 Supply Order Form**
- 31 Contact Information Audit**
- 44 QAP Discount Program**
- 47 2012 Canadian Board of Directors**
- 52 Manufacturer/Associate Member Directory**
- 59 Dates to Remember**
- 62 The Last Word**

NMEDA MISSION STATEMENT

Through our diverse membership NMEDA advocates and supports excellence in providing safe, reliable vehicles and modifications to enhance accessibility for people with special needs.



TYPE FONT: Gotham

ON THE COVER: © Jenna DeTrapani

BOARD OF DIRECTORS 2012



Sam Cook, President

Superior Van & Mobility
4734 Rockford Pl.
Louisville, KY 40216
502-447-8267 phone
502-657-193 fax
scook@superiorvan.com



Richard May, Southern Rep

United Access
2165 Hillshire Circle
Memphis, TN 38133
901-888-1010 phone
901-888-1009 fax
richard@unitedaccess.com



Mark DiRosa, Northern Rep

M.C. Mobility Solutions
7588 Tyler Blvd.
Mentor, OH 44060
800-951-6238 phone
440-942-8028 fax
mdirosa@mcmobilitysystems.com



Bob Lundin, Midwest Rep

IMED Mobility
200 East 1st St.
Tea, SD 57064
605-498-1601 phone
605-498-2202 fax
bob@imedmobility.com



Tom Lorentz, Secretary

Main Mobility
9580 Main Street
Clarence, NY 14031
716-759-6811 phone
716-759-6812 fax
tlorentz@mainmobility.com



Dan Drury, Western Rep

New Horizon Vans, Inc.
3825 Osuna N.E., Suite 1
Albuquerque, NM 87109
505-884-2492 phone
505-884-8007 fax
dan@newhorizonvans.com



Bill Koeblitz, Treasurer

MobilityWorks
810 Moe Drive
Akron, OH 43310
800-638-8267 phone
866-836-0043 fax
bkoeblitz@mobilityworks.com



Bill Siebert, Past President

Siebert Mobility, Inc.
405 Coolidge Street
Glenwood, IA 51535
712-527-3888 phone
712-527-9289 fax
siebert1@mchsi.com



Andrew Bayer, Mfg. Rep

Bruno Independent Living Aids
1780 Executive Drive
Oconomowoc, WI 53066
800-882-8183 phone
262-953-5501 fax
andrew.bayer@bruno.com



John Anschutz, Associate Rep.

Shepherd Center
2020 Peachtree Rd. NW
Atlanta, GA 30309
404-350-7720 phone
404-350-7356 fax
john_anschutz@shepherd.org



Nick Gutwein, Mfg. Rep.

Braun Corporation
631 West 11th Street
Winamac, IN 46996
574-946-4139 x321 phone
574-946-2322 fax
nick.gutwein@braunlift.com



David Hutchison, Canadian President

Sparrow Hawk Industries, Ltd.
675 Davenport Rd.
Waterloo, ON N2V 2E2
519-884-4295 phone
519-884-1924 fax
davidh@sparrowhawk.ca



Ron Mohr, Northern Rep

Clock Mobility
6700 Clay Ave.
Grand Rapids, MI 49548
800-732-5625 phone
616-698-9495 fax
ronm@clockconversions.com



Wheelchair Safety
Shouldn't Be Complicated.

Simplify with
TITAN

See why Titan Retractors are the ideal
Wheelchair Securement System.

Features like the unique yellow "locked" indicator tag along with an auto-lock and auto-tensioning retractor, help drivers effectively secure your passengers.

SURE-LOK  **K**[®]
Safe and Secure

www.sure-lok.com/titan





PRESIDENT'S LETTER

SAM COOK (SUPERIOR VAN & MOBILITY)

The NMEDA President, Sam Cook, is the owner of Superior Van & Mobility, which operates 7 stores in Kentucky, Indiana and Tennessee. Sam has many years of experience on the Board and has served as Vice President for the last 4 years. Sam believes that it is an exciting and challenging time to be in the Mobility Industry. As dealers, we get much more accomplished as a group than as individual dealers, which is why he feels so strongly about the power of NMEDA. Concerns or questions for the President may be directed to him at info@nmeda.org.

Hello everyone from your President.

To say there is a lot going on this year at NMEDA would be an understatement. The success of the National Mobility Awareness Month campaign was greater than anyone dreamed. Although the overwhelming number of visitors to our website caused us to stumble out of the gate, we recovered very well. The contest created a buzz throughout the country that this industry has not seen before. We learned many things during the month of May and are already planning for an even bigger and better National Mobility Awareness Month campaign in 2013.

This year many local media outlets covered our Local Hero stories and we even received national exposure on the 30 minute television program "It's Your Call with Lynn Doyle". Mike Savicki and I were honored to represent NMEDA on the show and feel that it helped shine a very favorable light on our industry. To conclude the campaign, the winners of the 3 Wheelchair Accessible Vans were featured on the nationally broadcast TV show, "The Daily Buzz".

I would like to thank EVOK Advertising and the NMEDA staff for all of their "behind the scenes" work that brought National Mobility Awareness Month to life. Also, a special thanks to Braun and VMI for donating their PR firms' time to the project. Lastly, the contest could not have happened without the donations of Vans and Conversions from Toyota, Chrysler, San Tan Honda, Braun, Bruno and VMI. Thanks to all!

“ To say there is a lot going on this year at NMEDA would be an understatement.”

In addition, NMEDA is once again sponsoring the PVA games which will be held in Richmond, VA in June. This is a great opportunity for NMEDA to build relationships with the PVA! At this event we are able to show off our products to the athletes and educate them about the importance of buying from their local NMEDA dealer. After the games, we will head over to Washington to meet with the VA and then Capital Hill to continue our talks and build relationships with members of Congress and their staff.

If you have ideas, suggestions or even complaints, don't keep them to yourself. It takes all of us to grow this industry, so please contact me anytime at scook@superiorvan.com or (502)410-1901.

***Attention NMEDA Members ...
come be one of the best!***



ACCESSIBLE VANS

of America LLC

“Linking Accessibility Nationwide”

Wheelchair Accessible Van Rental Network

Our members receive:

- Competitive insurance rates
- Legal rental contracts
- Nationwide marketing, networking & training

***If you are looking for a way to enhance
your Mobility dealership, come see what
AVA can do for you!***



Contact Accessible Vans of America



602-275-2798

www.AccessibleVans.com

Thanks To All Who Participated In May Mobility Awareness Month An Amazing



IV

112TH CONGRESS
2D SESSION

H. RES. 673

Expressing support for designation of May 2012 as "National Mobility Awareness Month".

IN THE HOUSE OF REPRESENTATIVES

JUNE 1, 2012

Mr. BARROW submitted the following resolution; which was referred to the Committee on Oversight and Government Reform

RESOLUTION

Expressing support for designation of May 2012 as "National Mobility Awareness Month".

Whereas millions of people in the United States experience mobility challenges due to injury or illness;

Whereas 6,000,000 veterans suffer from mobility challenges;

Whereas a majority of these individuals unfortunately report that inadequate transportation and mobility options are a major problem in their daily lives;

Whereas many people in the United States overcome mobility

The month of May might be over but the momentum initiated by National Mobility Awareness Month continues to roll along.

It is now official – introduced by U.S. Rep. John Barrow of Georgia, the 112th Congress designated the month of May as **National Mobility Awareness Month and it has been read into the Congressional Record.**



Alberto Cruz, Willimantic, CT.



Kenneth Davert, Bay City, MI.



Ronald Miner, Frankfort, IL.

CONGRATULATIONS TO OUR WINNERS!



Kenneth Davert from Bay City, MI. Alberto Cruz from Willimantic, CT. and Ronald Miner from Frankfort, IL. The winners were announced on The Daily Buzz, broadcast in 170 markets across the US and were joined by Sam Cook from NMEDA, Duane Galbreath from BraunAbility, Monique McGivney from VMI, Bill Burriss from Toyota and the spokesperson for National Mobility Awareness Month, Mike Savicki.

Making National Mobility Awareness Month a Success.



National Mobility Equipment Dealers Association | **Life Moving Forward**

LET THE NUMBERS SPEAK FOR THEMSELVES

Across the board the National Mobility Awareness Month promotion was an amazing success. From the number of stories we received to the number of website visits to the final tally of votes cast, the entire program is a step in the right direction to growing awareness about mobility solutions.

And speaking of numbers, when we put an ad value on all the publicity generated by National Mobility Awareness Month the dollar figures really add up. Vocus (a independent PR software program) reports \$1,040,645 ad value equivalency for the month of May. In addition, there was an added value of \$105,000 for the RLTV segment and the total number of CAP impressions was 45,398,886. That's the equivalent of over a million dollars in advertising.

1,702 Local Hero stories posted
2,656,871 Visitors to the website
1,433,680 Unique visitors
15,706,292 Page views
1,291,171 Votes were cast
86,185 Video views on YouTube
10,000 Fans in Facebook
8,250 Followers on Twitter
Over **7,500** news clips and segments

WE COULDN'T HAVE DONE IT WITHOUT YOU!

Toyota
Chrysler
BraunAbility
VMI

SanTan Honda
Ace Mobility
B&D Independence

Drive Master
Freedom Mobility
Sure Grip



We'd also like to say a big thank you to everyone who took part in the promotion and to all the NMEDA members and dealers who worked so hard in their local communities. It wouldn't have been successful without your help. We look forward to doing it all over again next year.

A recent poll was taken among the NMEDA members and over 75% of the membership believes that National Mobility Awareness Month was a worthwhile cause for NMEDA to sponsor and get involved in.



MobilityAwarenessMonth.com · 866.948.8341

NMEDA DEALER MEMBERS

UNITED STATES

ALABAMA

Q Griffin Medical Associates

213 Chestnut Street NW
Hartselle, AL 35640
256-751-1365
1,2,3

Q Gulf States Mobility

1647 Coosa River Parkway
Wetumpka, AL 36092
334-514-6590
1,3

Q MobilityWorks

3747 Pine Lane CI-459
Bessemer, AL 35022-5642
888-473-5402
1,3

Q Phase III Vans, Inc.

2015 Eastern Blvd
Montgomery, AL 36117
334-244-1011
1

Q Sylacauga Handicapped, Inc.

1304 Talladega Hwy.
Sylacauga, A 35150
256-249-3717
1,2,3

Q Team Adaptive Medical, Inc.

1251 Bolton's Branch Dr.
Mobile, AL 36606
251-471-1088
1,3

ARKANSAS

Accessibility Specialties, Inc.

1920 John Barrow Rd.
Little Rock, AR 72204
501-312-1000

Q Presidential Conversions

2887 No. College, Suite B
Fayetteville, AR 72703
479-521-8433
1,2,3

Q Presidential Conversions

2500 Commerce Drive,
Bldg. A, Suite B
Jonesboro, AR 72401
870-933-7270
1,2

Q Siebert Mobility Inc.

712 Hwy 5 N.
Benton, AR 72019
501-316-2466
1,2

ARIZONA

A.D.E. Industries, Inc.

3621 S. Palo Verde
Tucson, AZ 85713
520-571-7156

Q Ability Center

23606 N. 19th Ave.
Phoenix, AZ 85085
623-879-0800
1,3

Q Ability Center

4720 N. La Cholla Blvd
Tucson, AZ 85705
520-293-3596
1,3

Q Dignified Motors LLC

3422 East Roeser, #A-102
Phoenix, AZ 85040
877-344-6686
1,3

Q Handicap Vehicle Specialists

3306 E. Washington, #106
Phoenix, AZ 85034
602-275-3325
1,3

Q Quality Vans

1865 S. Indianbend Road
Tempe, AZ 85281
480-464-7007
1,2

CALIFORNIA

Q Ability Center

11600 Western Avenue
Stanton, CA 90680
714-890-8262
1,3

Q Ability Center

6550 Freeport Blvd. Suite A
Sacramento, CA 95822
916-392-1196
1,2,3

Q Ability Center

4797 Ruffner Street
San Diego, CA 92111
858-541-0552
1,2,3

Q Access Options, Inc.

1253 Birchwood Dr.
Sunnyvale, CA 94089
408-734-5438
1

Q Access Options, Inc.

109 Lee Road Suite D
Watsonville, CA 95076
831-722-6804
1,2,3

Q Adaptive Driving Systems

3548 Empleo
San Luis Obispo, CA 93401
805-549-7996
1,2,3

Q AERO MOBILITY

P.O. Box 1631
Orange, CA 92856
714-973-8600
1

Q Better Life Mobility

8130 Parkway Drive
LaMesa, CA 91942
619-474-4072
1

Better Life Mobility

1370 Dodson Way
Riverside, CA 92507
951-686-3152

Q Classic Vans, Inc.

dba Mobility Vans USA
25700 Mission BL
Hayward, CA 94544
510-538-3150
1

Q Driving Specialties

2216 Cemo Circle #A
Rancho Cordova, CA 95670
916-635-2765
1

Q Driving Specialties, Ltd.

215 Commercial St.
Vallejo, CA 94589
707-553-1515
1,2,3

Economy Medical

114 Center Avenue
Pacheco, CA 94553
925-671-4800

Q Gary E. Colle, Inc. dba

Goldenboy of San Diego
12300 Stowe Dr. Suite A
Poway, CA 92064
858-748-9414
1,3

Q Mac's Lift Gate, Inc.

2715 Seaboard Ln.
Long Beach, CA 90805
562-634-5962
1,2,3

Q Mobile Help

711 S. Allen St.
San Bernardino, CA 92408
909-383-3883
1,3

Q MobilityWorks

2010 Duane Ave.
Santa Clara, CA 95054
888-473-5402
1,3

Q MobilityWorks

7720 Sepulveda Blvd.
Van Nuys, CA 91405
888-473-5402
1,3

Q Modesto Mobility Center

1025 Lone Palm Ave. Ste 5A-B
Modesto, CA 95351
209-577-1069
1,2,3

Q Nor-Cal Mobility, Inc.

890 Cowan Road, Suite B
Burlingame, CA 94010
800-225-7361
1

Q Nor-Cal Mobility, Inc.

120 N. Diamond St.
Fresno, CA 93701
800-225-7361
1

Q Nor-Cal Mobility, Inc.

3127 Fite Circle, Suite B
Sacramento, CA 95827
800-225-7361
1

Q Nor-Cal Mobility, Inc.

1300 Nord Avenue
Chico, CA 95926
800-225-7361
1,2,3

Q Sacramento Van Conversions & Mobility

5821 Florin Perkins Rd.
Sacramento, CA 95828
916-381-8267
1

The Mobility Specialist, Inc.

490 Capricorn Street
Brea, CA 92821
714-674-0480

COLORADO

Q Freewheel Mobility

9500 W. 49th Ave. C107
Wheat Ridge, CO 80033
303-467-9981
1,2,3

Q Freewheel Mobility

4655 Town Center Dr.
Colorado Springs, CO 80916
719-262-6640
1,2,3

Mobility Auto Center LLD

215 South 15th Street
Grand Junction, CO 81501
970-243-7552

Q Performance Mobility

333 East 76th Ave.
Denver, CO 80229
303-288-0140
1,2,3

Q Performance Mobility

6285 Corporate Drive
Colorado Springs, CO 80919
719-590-1400
1

CONNECTICUT

Q Advanced Wheels of Technology

15F International Dr., Box 908
East Granby, CT 06026
860-653-8064
1,2,3

Q Ride-Away

104 Pitkin St.
E. Hartford, CT 06108
888-RIDE-AWAY
1,3

Q Wheelchair Getaways

32 Stony Hill Rd.
Bethel, CT 06801
203-790-9998
1,3

DELAWARE

True Mobility, Inc.

773 S. DuPont Hwy.
New Castle, DE 19720
302-836-4110

FLORIDA

Q Access by Skip LLC

1731 Fern Palm Dr. 1A
Edgewater, FL 32132
386-428-6677
1,3

Q Advanced Driving Systems

662 Capital Cir. N.E.
Tallahassee, FL 32301
850-671-2300
1,2,3

Q Advanced Vehicle Modifications

2520 NW 6th Street
Ocala, FL 34475
352-622-4467
1,3

Q America's Mobility Solution

1873 Nova Road
Holly Hill, FL 32117
386-672-1990
1

Q Auto Mobility Sales

5601 NW 9th Ave #203
Ft. Lauderdale, FL 33309
954-974-7028
1

Q Auto Mobility Sales

1925 10th Ave. N. Unit 1
Lake Worth, FL 33461
561-586-1997
1

Q KEMPF Inc.

225 S. 78th Street
Tampa, FL 33619
813-630-0409
1,3

Med Repairs, Inc.

3120 Aviation Blvd.
Vero Beach, FL 32960
772-569-2901

Q Mike Erdman Toyota

1545 E Merritt Island Cswy.
Merritt Island, FL 32952
321-454-4430
1,2

Q MITS at Custom Mobility

7199 Bryan Dairy Road
Largo, FL 33777
727-524-1300
1,3

Q Mobility America

5181 Hwy 98 N.
Lakeland, FL 33809
863-816-1513
1

Q Mobility Freedom Inc.

20354 U.S. Hwy 27
Clermont, FL 34715
352-429-3972
1,2

Q Mobility Freedom, Inc.

2323 N. State Street #49
Bunnell, FL 32110
386-586-5495
1,3

Q Mobility Freedom, Inc.

8203 Ulmerton Rd.
Largo, FL 33771
727-521-4248
1,3

Q Mobility Freedom, Inc.

7444 Narcoossee Rd. Ste 406
Orlando, FL 32822
407-674-8778
1,2,3

Mobility Styles Inc.

dba Mobility Express
9300 Cortez Blvd.
Weeki Wachee, FL 34613
352-597-4546

Q Mobility Transportation Systems

4010 E. Hillsborough Ave.
Tampa, FL 33610
813-246-9116
1,2,3

Q MobilityWorks

2727 St. Johns Bluff Rd.
Jacksonville, FL 32246
888-473-5402
1,3

Q Movin' On Mobility

342 Pike Rd. Suite #26
West Palm Beach, FL 33411
561-881-5600
1,3

Q Movin' On Mobility

12530 Metro Pkwy
Ft. Myers, FL 33912
239-275-1900
1,2,3

Q Ocean Conversions & Mobility

750 E Sample Rd, Bldg 1 Ste 5
Pompano Beach, FL 33064
954-942-6033
1,2,3

Q Ocean Conversions of

Ft. Myers, Inc.
5751 Zip Drive
Ft. Myers, FL 33905
239-936-6333
1,2,3

Q Phase III Mobility

4333 Gulf Breeze Pkwy
Gulf Breeze, FL 32563
866-514-8777
1,2,3

Q Piper Medical, Mobility & Accessibility

1885-B NE 149th Street
North Miami, FL 33181
305-940-2030
1,3

Q R & M Mobility

9580 Nims Lane
Pensacola, FL 32534
850-479-1766
1,2,3

Q Ride-Away

8706D East Broadway Ave
Tampa, FL 33619
888-RIDE-AWAY
1

Q Specialty Vehicles, Inc.

685 Broad St.
Pensacola, FL 32534
850-477-7645
1

Q Sunset Mobility

8415 S.W. 129 Terrace
Miami, FL 33156
305-234-0071
1,2,3

Q Team Adaptive, Inc.

1503 Foster Ave.
Panama City, FL 32405
850-522-0059
1

Q Wheelchair Vans of Florida

1275 US 41 Bypass South
Venice, FL 34285
941-451-8194
1

GEORGIA

Q Adaptive Driving Solutions

3027 Riverwatch Lane
Augusta, GA 30907
706-364-2688
1,2,3

Q AMS Vans, Inc.

5555 Oakbrook Pkwy Bldg. 500
Norcross, GA 30093
770-729-9400
1

Q Custom Mobility Van & Lift

315 Whitehead Rd.
Athens, GA 30606
706-353-1099
1,2,3

Q MobilityWorks

1255 Kennestone Circle Ste. 100
Marietta, GA 30066
800-444-9100
1,3

Q Quail Country Customs

731 S. Westover Blvd.
Albany, GA 31707
229-432-7258
1

Q Quail County Customs, Inc.

2635 Hwy 247 Connector
Byron, GA 31008
478-956-1225
1

Q R & R Van Lift Sales & Service

2130 Sigman Road
Conyers, GA 30012
770-483-0767
1,2,3

IOWA

Q Siebert Mobility Inc.

3450 SE Miede Drive, Suite 1
Grimes, IA 50111
515-986-3010

Q Siebert Mobility Inc.

3554 Dolphin Dr.
Iowa City, IA 52240
319-351-3159
1

Q Siebert Mobility Inc.

405 Coolidge St.
Glenwood, IA 51534
712-527-3888
1,2,3

Q Total Mobility

2406 W. 2nd Avenue
Indianola, IA 50125
515-961-0575
1,2,3

ILLINOIS

Q Custom Van Conversions & Mobility

3720 Oakton St.
Skokie, IL 60076
847-679-8261
1,2,3

Q MobilityWorks

23855 W. Andrew Road
Plainfield, IL 60585
888-473-5402
1,3

Q MobilityWorks

155 E. North Ave.
Villa Park, IL 60181
888-473-5402
1,3

MobilityWorks

5050 Dempster
Skokie, IL 60077
888-473-5402

NMEDA DEALER MEMBERS

Q Southern Bus and Mobility

12950 Koch Lane
Breese, IL 62230
618-526-4131
1,3

Q United Access

706 W. Bradley
Champaign, IL 61820
217-398-1053
1,3

Q United Access

2924 N. Dirksen Parkway
Springfield, IL 62702
888-706-1010
1,3

INDIANA

Q ADM Mobility Solutions, Inc.

8360 W. Washington St.
Indianapolis, IN 46231
317-481-8707
1,3

Q McCrocklin Ford Sales, Inc.

810 W. Mill Street
Middletown, IN 47356
765-354-2261
1,3

Q Superior Van & Mobility

5410 S. Madison Ave.
Indianapolis, IN 46227
877-405-9929
1,2,3

Q Superior Van & Mobility

3725 W. Cleveland Rd Ste 400
South Bend, IN 46628
877-405-9929
1,3

Q Superior Van & Mobility

3414 Interstate Drive
Evansville, IN 47715
877-405-9929
1,3

Q Superior Van & Mobility

2218 Contractors Drive
Fort Wayne, IN 46818
877-405-9929
1,3

KANSAS

Q Banner Mobility Resources

231 SE 53rd St. Ste C
Topeka, KS 66609
785-235-3070
1

Q Jay Hatfield Mobility, LLC

200 S. East Avenue
Columbus, KS 66725-1955
800-545-4227
1,2,3

Q Kansas Truck Equipment Co.

1521 S. Tyler Road
Wichita, KS 67209
316-722-4291
1,2,3

Q United Access

7921 Bond Street
Lenexa, KS 66214
913-894-8080
1,3

KENTUCKY

Q C & C Ford - Mercury

Post Office Box 249
Sturgis, KY 42459
800-332-6696
1,2

Q Marilyn's Medical Freedom

4860 Old Mayfield Rd.
Paducah, KY 42003
270-534-9713
1

Q Movin On Mobility Mid America, LLC

3301 Fern Valley Road
Louisville, KY 40213
502-964-3556
1

Q Pennyrile Home Medical, Inc.

307 E. Main St.
Cadiz, KY 42211
270-522-8002
1

Q Superior Van & Mobility

1180 E. New Circle Rd.
Lexington, KY 40505
877-405-9929
1,3

Q Superior Van & Mobility

4734 Rockford Pl.
Louisville, KY 40216
877-405-9929
1,2,3

Q Thomas Medical Equipment

P.O. Box 18010
Louisville, KY 40213
502-459-6006
1,2

LOUISIANA

Q Acadiana Handicap Solutions

224 East Pinhook Rd.
Lafayette, LA 70501
337-289-3004
1,2,3

Q Access Vans of LA, Inc.

17300 Hwy. 77
Grosse Tete, LA 70740
225-648-2647
1,2,3

Q Access Vans of Louisiana

1901 Westbank Expwy, Ste 500
Harvey, LA 70058
504-362-9491
1

Q Crescent Vans, Inc.

2424 Hickory Ave.
Metairie, LA 70003
504-738-2634
1,2,3

Q Fastserv Medical Monroe

112 Summer Lane
West Monroe, LA 71291
318-396-3366
1,3

Q FastServ Medical Bossier

3050 Knolin Dr. #1
Bossier City, LA 71112
318-741-9586
1,2,3

Kenny's Accessible Vans LLC

2001 Wooddale Blvd.
Baton Rouge, LA 70806
225-926-2403

MASSACHUSETTS

Q Adaptive Mobility Equipment

1551 Fall River Ave. (Rte. 6)
Seekonk, MA 02771
508-336-2556
1,3

Q Automotive Innovations, Inc.

4 First Street
Bridgewater, MA 02324-0474
508-697-8324
1,2,3

Q New England Wheels Inc.

33 Manning Road
Billerica, MA 01821
978-663-9724
1,2,3

Q Ride-Away

249 E. Washington St. N.
Attleboro, MA 02760
888-RIDE-AWAY
1,3

Q Ride-Away

333 Boston Prov. Hwy., Bldg. C
Norwood, MA 02062
888-RIDE-AWAY
1,3

MARYLAND

Q AA Eastern Mobility, Inc.

P. O. Box 415
Woodsboro, MD 21798
301-845-4188
1

Auto Assist, Inc.

5002 Lehigh Ave.
College Park, MD 20740
301-699-2238

Q BEDCO Mobility

6300 Falls Rd.
Baltimore, MD 21209
410-825-1440
1

Q Koons Ford of Annapolis

2540 Riva Rd.
Annapolis, MD 21401
410-224-2100
1,3

Q Oneness Mobility Services

7620 A Penn Belt Dr.
Forestville, MD 20747
866-570-6686
1,2,3

Q Ride Away

11409 Maryland Ave.
Beltsville, MD 20705
888-RIDE-AWAY
1,3

Q TTI Mobility Products

404-D Irl Lane
Fruitland, MD 21826
800-576-4323
1

MAINE

Q Ride-Away

32 Lewiston Road, Unit 2B
Gray, ME 04039
888-RIDE-AWAY
1,3

MICHIGAN

Q Access Mobility Center

7620 Eastman Avenue
Midland, MI 48642
989-633-6100
1

Q Advantage Mobility Outfitters

3990 Second St.
Wayne, MI 48184
734-595-4400
1,2,3

Q Clock Conversions

587 W. Blue Star Drive
Traverse City, MI 49684
231-943-9890
1

Q Clock Conversions

6700 Clay Ave.
Grand Rapids, MI 49548
800-732-5625
1,2,3

Q Clock Conversions

5540 S. Pennsylvania Ave. Ste 11
Lansing, MI 48911-4012
517-272-4488
1

Freedom Motors USA

740 Watkins Road
Battle Creek, MI 49015
888-625-6335

Q MobilityWorks

1965 East Avis
Madison Heights, MI 48071
888-473-5402
1,3

Q MobilityWorks

8175 Gratiot Rd.
Saginaw, MI 48609
888-473-5402
1,3

The Creative Mobility Group

32217 Stephenson Hwy.
Madison Heights, MI 48071
248-577-5430

MINNESOTA

Q Cummings Mobility

1755 W County Road C.
Roseville, MN 55113
651-633-7887
1,3

Q Cummings Mobility Conversions & Supply Inc.

6540 Jansen Ave. NE
Albertville, MN 55301
763-497-0103
1,2,3

Q IMED Mobility

1915 County Road C
Roseville, MN 55113
651-635-0655
1,2,3

Q Rollx Vans

6591 W. Highway 13
Savage, MN 55378
800-956-6668
1,2,3

Wheelchairs Plus, Inc.

65 Third Street NE
Waite Park, MN 56387
218-326-1833

Wheelchairs Plus, Inc.

502 SE 10th Street
Grand Rapids, MN 55744
218-326-1833

MISSOURI

Q D.W. Auto & Home Mobility Specialties

1208 N. Garth Ave.
Columbia, MO 65203
800-568-2271
1,2,3

Q Handicap Conversions, Inc.

8200 NW 97th Terrace
Kansas City, MO 64153
816-471-0305
1,2,3

Mid America Coach, Inc.

8809 East State Road 350
Kansas City, MO 64133
816-734-5000

Q Southern Bus & Mobility, Inc.

80 South Highway Dr.
Valley Park, MO 63088
636-825-0700
1,3

Q United Access

9389 Natural Bridge Rd
St. Louis, MO 63134
314-426-1010
1,2,3

Q United Access

618 Jackson St.
Columbia, MO 65203
573-874-2214
1,3

Q United Access

1389 N. Cedarbrook
Springfield, MO 65802
417-890-1043
1,3

Q United Access

10232 A Rahning Road
Sunset Hills, MO 63127
314-989-1010
1

MISSISSIPPI

Q Grace Healthcare Inc.

1120 Broad Avenue
Gulfport, MS 39501
228-863-3331
1

Q Handicapable Vans, Inc.

5516 North State Street
Jackson, MS 39206
601-981-0042
1,2,3

Q J's Mobility Unlimited, Inc.

3880 Flowood Dr.
Flowood, MS 39232
601-939-2112
1,2,3

Q Mobility Systems, Inc.

2857 Oak Grove Road
Hattiesburg, MS 39402
601-264-0609
1,2,3

Q NTC Delta, LLC

3742 Hwy 82 West
Greenville, MS 38701
662-378-2648
1,2

Q Team Adaptive, Inc.

978 Tommy Munro Dr.
Biloxi, MS 39532
228-388-5700
1

Q Total Mobility Concepts LLC

1204 S. Gloster Street
Tupelo, MS 38801
662-269-2068
1

MONTANA

Q G & J Enterprises

3353 Old Hardin Rd
Billings, MT 59101
406-248-5767

NEBRASKA

Q Kohll's Mobility & Rehab

Equipment
12729 Q Street
Omaha, NE 68137
402-408-1330
1,2,3

Q Mobility Motoring LLC

14450 Meadows Blvd. Suite 2
Omaha, NE 68138
402-884-3333
1

NEW HAMPSHIRE

Q Ride-Away

54 Wentworth Ave.
Londonderry, NH 03053
888-RIDE-AWAY
1,2,3

NEW JERSEY

Q Accessible Vans and Mobility

2303 Wallace Blvd.
Cinnaminson, NJ 08077
856-829-9449
1,3

Q Brunswick Automotive Professionals

1500 US 1 North
North Brunswick, NJ 08902
732-545-6300
1,2,3

Q Drive-Master

37 Daniel Road West
Fairfield, NJ 07004
973-808-9709
1,2,3

Q Fun Truck'n Mobility

255 Route 46 West
Saddle Brook, NJ 07663
973-546-1900
1,2,3

Q MobilityWorks

5105 Rts. 33/34
Farmingdale, NJ 07727
732-919-1444
1,3

MV-1 of South Jersey

1006 White Horse Pike
Oaklyn, NJ 08107
856-983-0600

Q Performance Van Shop, Inc.

1549 Gateway Blvd
Woodbury, NJ 08096
856-848-3470
1,2,3

NEW MEXICO

Highland Conversions LLC

417 Adams St., S.E.
Albuquerque, NM 87108
505-232-8629

Q New Horizon Vans, Inc.

3825 Osuna NE Suite 1
Albuquerque, NM 87109
505-884-2492
1,2,3

Southwest Lift Installation

315 B Juan Tabo Blvd. NE
Albuquerque, NM 87123
505-891-3346

NEVADA

Q Ability Center

6001 S. Decatur Blvd. Suite N
Las Vegas, NV 89118
702-434-3030
1,3

Q Better Life Mobility Center

2695 S. Decatur Blvd. Ste 100
Las Vegas, NV 89102
702-876-9606
1

Q Nevada Seating & Mobility

7875 N. Virginia Unit E
Reno, NV 89506
775-887-1955
1

NEW YORK

Q Abilities Unlimited of NY

90 E. Jeffry Blvd.
Deer Park, NY 11729
800-664-8434
1,2,3

Q Advance Mobility

4214 Glenwood Road
Brooklyn, NY 10573
718-253-1212
1,2

Q Agor Enterprises

1241 Erie Blvd. W.
Syracuse, NY 13204
315-510-4272
1

Q Agor Enterprises, Inc

951 Panorama Trail South
Rochester, NY 14625
585-385-2556
1

Q AutoCrafting Mobility Solutions of Rochester LLC

997 Beahan Road
Rochester, NY 14624
585-427-7220
1,2,3

NMEDA DEALER MEMBERS

Q Boulevard Van City
2708 Niagara Falls Blvd.
Wheatfield, NY 14304
716-731-4335
1,2,3

Q Bussani Mobility
500 Central Ave.
Bethpage, NY 11714
516-938-5207
1,2,3

Q Bussani Mobility
501 Concord Avenue
Mamaroneck, NY 10543
914-835-8267
1,3

Q Craftmen Mobility Systems
570 Hance Rd.
Binghamton, NY 13903
607-669-4530
1,3

Q Fenton Mobility Products
1209 East Second Street
Jamestown, NY 14701
716-484-7014
1,2

Q Main Mobility
9580 Main Street
Clarence, NY 14031
716-759-6811
1,2,3

Q Mobility Services, Inc.
19-57 Steinway St.
Astoria, NY 11105
718-267-2921
1,2

Q MobilityWorks
1615 Central Avenue
Albany, NY 12205
888-473-5402
1,2,3

MV-1 of Upstate New York
1268 State Rte. 29
Greenwich, NY 12834
518-692-2241

Q Penn York Mobility
69 Main St.
Binghamton, NY 13905
607-773-3622
1,3

Q Specialty Conversions, Inc.
615 Sunrise Hwy.
West Babylon, NY 11704
631-321-4196
1,2,3

Q Tim's Trim, Inc.
25 Bermar Pk
Rochester 14624
585-429-6270
1,2,3

NORTH CAROLINA

Care Solutions
110-B Edney Street
Hendersonville, NC 28792
828-698-9844

Q Carolina Mobility Sales, LLC
4025 Queen City Dr.
Charlotte, NC 28208
704-399-0900
1,2,3

Freedom Mobility Aids
205 Cedar Lane
Clemmons, NC 27012
336-766-8520

Q Ilderton Conversion of Charlotte
5518 Westpark Dr.
Charlotte, NC 28217
704-523-2022
1,2,3

Q Ilderton Dodge/Conversion Co.
701 S. Main St.
High Point, NC 27261
336-841-6100
1,2,3

Q Mountain Adaptive/The Van Shop
35 Dogwood Rd.
Asheville, NC 28806
828-670-1111
1,2,3

**Q Stalls Medical, Inc.
dba Adaptive Vans Inc.**
5995-119 Chapel Hill Rd.
Raleigh, NC 27607
919-233-0732
1

Q Van Products
2521 Noblin Road
Raleigh, NC 27604
919-878-7110
1,3

OHIO

Q Columbus Mobility Specialists
6330 Proprietors Rd., Suite C
Worthington, OH 43085
614-825-8996
1,2,3

Q Key Mobility Services
1944 U.S St. Rt. 68 N.
Xenia, OH 45385
800-539-5438
1

Q M.C. Mobility Systems
214 Valley St.
Dayton, OH 45404
937-222-5001
1

Q M.C. Mobility Systems
7588 Tyler Blvd
Mentor, OH 44060
800-951-6238
1,2

Q M.C. Mobility Systems
7233 Industrial Pkwy
Plain City, OH 43064
800-834-8301
1,3

Q M.C. Mobility Systems
10691 Reading Rd.
Evendale, OH 45241
513-469-8220
1

Q Marietta Mobility
211 South 8th Street
Marietta, OH 45750
800-690-4950
1,2,3

Q MobilityWorks
1020 Laskey Rd.
Toledo, OH 43612
888-473-5402
1,3

Q MobilityWorks
12117 Princeton Pike
Cincinnati, OH 45246
888-473-5402
1,3

Q MobilityWorks
810 Moe Dr.
Akron, OH 44310
888-473-5402
1,3

Q MobilityWorks
1500 Canton Road #208
Canton, OH 44312
888-473-5402
1,3

Q Modified Vehicle Specialists
2705 Nebraska Avenue
Toledo, OH 43607
419-535-1850
1,2,3

OKLAHOMA

Q Handi-Cap Aids Company
730 W. Hefner Rd.
Oklahoma City, OK 73114
405-842-0511
1,2,3

**Handicapped Vehicle
Services Unlimited**
7215 E. 46th St.
Tulsa, OK 74145
918-622-8400

Q Newby-Vance Mobility
5632 S. Division Street
Guthrie, OK 73044
405-282-2113
1,3

OREGON

All in One Mobility
1640 W. 7th Avenue
Eugene, OR 97402
541-246-8665

Q All in One Mobility
12833 NE Airport Way
Portland, OR 97230
503-255-5005
1

Q Mobility Access Options, Inc.
4938 Crater Lake Ave.
Central Point, OR 97504
541-245-4846
1

Q MPJ Mobility
3574 Marcola Road
Springfield, OR 97477
541-726-4001
1,3

Q Performance Mobility
4347 NW Yeon Ave.
Portland, OR 97210
503-243-2940
1,2,3

Q R & J Mobility Services, Inc.
155 "E" Street
Independence, OR 97351
503-838-5520
1,2,3

PENNSYLVANIA

Q Garnon Mobility Vehicles
1617 Peninsula Dr.
Erie, PA 16505
814-833-6000
1,2,3

Q Keller Wheelchair Lifts
197 Main St.
Luzerne, PA 18709
570-288-1004
1,2,3

Q Keystone Coach Works
4786 Library Rd.
Bethel Park, PA 15102
412-833-1900
1,2,3

Q Keystone Mobility
8118 Adams Drive
Hummelstown, PA 17036
717-482-8140
1,2,3

Q M.I.T.S. Corp.
11448 N. Main St. Ext.
Glen Rock, PA 17327
717-235-5899
1

Q MobilityWorks
1090 Mossie Blvd.
Wall, PA 15148
888-473-5402
1,3

Q Ride-Away
2460 General Armistead Ave.
Ste. 100-150
Norristown, PA 19403
888-RIDE-AWAY
1,3

Q Total Mobility Services
7917 Derry St. Suite 124
Harrisburg, PA 17111
800-558-7408
1,3

Q Total Mobility Services, Inc.
4785 Penn Ave. Box 7
Boswell, PA 15531
814-629-9935
1,2,3

Q VCI Mobility
925 S. Trooper Rd.
Norristown, PA 19403
610-666-9100
1,2,3

Q VCI Mobility
6475 Ruch Road
Bethlehem, PA 18017
610-837-0707
1,2,3

PUERTO RICO

Equipos Pro Impedidos de P.R., Inc.
GPO Box 9734
Caguas, PR 00725
787-746-7667

SOUTH CAROLINA

Q Carolina Mobility Sales LLC
3624 Fernandina Road
Columbia, SC 29210
803-791-7791
1,3

Q Ilderton Conversion of Charleston LLC
8550 Rivers Avenue
North Charleston, SC 29406
843-576-0414
1,2,3

Q Southeastern Health Plus
11816 Hwy 17 Bypass
Murrells Inlet, SC 29576
843-651-5795
1

SOUTH DAKOTA

Black Hawk Vans
3156 Haines Rd.
Rapid City, SD 57701
605-342-2104

Q IMED Mobility
200 East 1st St.
Tea, SD 57064
605-498-2200
1

TENNESSEE

Q Apple Independence Mobility
306 N. Willow Ave.
Cookeville, TN 38501
877-528-5788
1,3

Q Apple Independence Mobility
1152 Pine St.
Lebanon, TN 37087
877-528-5788
1,3

Q MobilityWorks
1325 Mackey Branch Drive
Chattanooga, TN 37421
888-473-5402
1,3

Q MobilityWorks
173 Industrial Dr.
Lavergne, TN 37086
888-473-5402
1,3

Q Mountain Adaptive
3705 Bristol Hwy
Johnson City, TN 37601
423-283-9111
1,3

Q Superior Van & Mobility
10640 Braden Dickey Lane
Knoxville, TN 37932
877-405-9929
1

Q United Access
2165 Hillshire Circle
Memphis, TN 38133
901-888-1010
1,2,3

TEXAS

Q Above & Beyond Mobility
P.O. Box 132
Ben Wheeler, TX 75754
903-833-2639
1

Q Access 2 Mobility, Inc.
12406 SH 155 South
Tyler, TX 75703
877-254-5438
1

Access Mobility
6610 North Highway 6
Waco, TX 76712
254-752-4397

Q Adaptive Driving Access
6836 N Sam Houston Pkwy W
Houston, TX 77064
713-874-9100
1,2,3

Q Adaptive Driving Access
3430 E Sam Houston Pkwy S
Pasadena, TX 77505
281-487-1969
1,2,3

Q Advanced Mobility Systems of TX
2110 N. Beach
Ft. Worth, TX 76111
817-429-1273
1,2,3

Q Advanced Mobility Systems of TX
3029 E. Meadows Blvd., A-2
Mesquite, TX 75150
972-270-7114
1,3

Advanced Mobility Systems of TX
239 Commercial Drive
Buda, TX 78610
512-295-3800

Q Alamo Mobility Inc.
6473 DeZavala Road
San Antonio, TX 78249
210-697-8884
1,2,3

Q American Lift Aids
2310 Calder
Beaumont, TX 77702
409-832-3400
1,2,3

Q American Lift Aids, Inc.
2407 W. Southwest Loop 323
Tyler, TX 75701
903-581-8844
1,2,3

Auto & Home Mobility Solutions
8885 State Highway 21 East
Bryan, TX 77808
979-589-2005

Q Lift Aids, Inc.
1500 Westpark Way
Euleless, TX 76040
817-835-0035
1,2,3

Q Marshall Mobility Plus
120 North 20th Street
McAllen, TX 78501
956-971-8646
1,3

Q Mobility Headquarters of Texas
14300 NW Freeway Ste B-10
Houston, TX 77040
713-939-9922
1,3

Mobility Outfitters, Inc.
2601 Summit Avenue Ste 300
Plano, TX 75074
972-509-5233

Q Mobility Plus
1789 Upland Dr.
Houston, TX 77043
713-468-4683
1,2,3

Q Para Driving Aids
10624 N. IH 35
San Antonio, TX 78233
210-655-5438
1,2,3

The Mobility Store, Inc.
5544 Kostoryz Rd.
Corpus Christi, TX 78415
361-814-5438

Q United Access of Dallas
175 E. I-30
Garland, TX 75043
972-240-8839
1,2,3

UTAH

Q Freewheel Mobility
680 N. 1000 W, Unit 8
Centerville, UT 84014
801-294-0550
1,3

VIRGINIA

Q Independent Lifestyles
4880 S. Amherst Hwy
Madison Heights, VA 24572
434-846-7510
1,3

Q M.I.T.S. of VA
2075 W. Main St.
Waynesboro, VA 22980
540-932-7300
1

Q Mobility Center of VA
7450 Midlothian Turnpike.
North Chesterfield, VA 23225
804-231-7774
1,2,3

Q Mobility Plus, Inc. of Virginia
323 South College Avenue
Salem, VA 24153
540-389-3400
1,3

Q Ride-Away
6059 Virginia Beach Blvd.
Norfolk, VA 23502
888-RIDE-AWAY
1,3

Q Ride-Away
232 E. Belt Blvd., #100
Richmond, VA 23224
888-RIDE-AWAY
1,3

VERMONT

Q Ride-Away
5C David Drive
Essex Junction, VT 05452
888-RIDE-AWAY
1,3

NMEDA DEALER MEMBERS

WASHINGTON

Q Absolute Mobility Center

21704 - 87th Ave. SE
Woodinville, WA 98072
425-481-6546
1,2,3

Q Access Mobility Systems dba JDR Corporation

7202 Evergreen Way
Everett, WA 98203
425-353-6563
1,3

Accessible Autos

13718 Mukilteo Speedway
Lynwood, WA 98087
425-609-1505

Q Goldenwest Mobility

1815 E. Francis
Spokane, WA 99208
509-484-3842
1

Q Kersey Mobility Systems

6015 160th Ave. E.
Sumner, WA 98390
253-863-4744
1,2,3

Q Paul Parish Limited

6400 W. Okanogan Ave.
Kennewick, WA 99336
509-735-9820
1,3

WISCONSIN

Q A & J Mobility

4125 Terminal Dr
McFarland, WI 53558
608-579-1500
1

Q A & J Mobility

333 Washington Street
Valders, WI 54245
920-775-9333
1,2,3

Q A & J Mobility

2650 Prospect Drive
Eau Claire, WI 54703
715-833-9830
1,3

Q A & J Vans dba A & J Mobility

3058 Helsan Drives
Richfield, WI 53076
800-517-1024
1,3

Q Advantage Mobility & Services, LLC

2833 Stanley St.
Stevens Point, WI 54481
715-341-2712
1,2,3

Q GT Mobility and Services

844 Ontario Road
Green Bay, WI 54311
920-491-8384
1,2,3

Q MobilityWorks

N8 W22195 Johnson Dr Ste. 130
Waukesha, WI 53186
888-473-5402
1,3

WEST VIRGINIA

Access & Mobility Products

302 Virginia Avenue
Huntington, WV 25701
304-522-6808

WYOMING

Q Frontier Access & Mobility Systems, Inc.

1207 E. Pershing Blvd.
Cheyenne, WY 82001
307-637-7663
1

CANADA

ALBERTA

Q ECO Medical

18303 107 Avenue
Edmonton, AB T5S 1K4
780-483-6232
1

Q Shoppers - H & H Care

#1-2720 - 12th St. NE
Calgary, AB T2E 7N4
403-250-2200
1,2,3

Q Shoppers Home Healthcare

8303-Gold Care Med
4619 - 91 Ave. N.W.
Edmonton, AB T6B 2M7
780-468-4002
1,2,3

BRITISH COLUMBIA

Advanced Mobility Products

101-8620 Glenlyon Parkway
Burnaby, BC V5J 0B6
604-293-0002

Q Can Am Mobility

158 Old Vernon Rd
Kelowna, BC V1X 4R2
250-491-0003
1

Q PG Surg-MED Ltd

1749 Lyon Street
Prince George, BC V2N 1T3
250-564-2240
1

Q PG Surg-Med Ltd.

4204 25th Ave.
Vernon, BC V1T 1P4
250-549-7288
1

Shoppers Home Health Care

#101 - 8289 North Fraser Way
Burnaby, BC V3N 0B9
604-326-1117

NEW BRUNSWICK

Q Malley Industries, Inc.

1100 Aviation Avenue
Dieppe, NB E1A 9A3
506-859-8591
1,2,3

Shopper Home Healthcare

535 Edinburgh Dr.
Moncton, NB E1E 4E3
506-388-9679

NOVA SCOTIA

Q Harding Medical Supplies

24 Elmwood Drive
Moncton, NS E1A 3W6
506-855-5200
1

Q MEDChair - Halifax

3447 Kempt Rd
Halifax, NS B3K 5T7
902-484-2002
1

ONTARIO

Q Courtland Mobility

1355 Artisans Court, Unit B
Burlington, ON L7L 5Y2
800-354-8138
1,2,3

Q Creative Carriage Ltd

6 Ridgeview St.
St. George, ON NOE 1N0
800-392-8403
1,2

Q Goldline Mobility & Conversions

1759 Trafalgar St.
London, ON N5W 1X4
519-453-0480
1,2,3

Q Kino Mobility, Inc.

3-1140 Sheppard Ave. W.
Toronto, ON M3K 2A2
416-635-5873
1,3

Q Medichair Home Healthcare

1460 Bishop Street N
Cambridge, ON N1R 7N6
519-623-9930

MEDChair Temiskaming Ltd.

211 Armstrong Street
New Liskeard, ON P0J 1P0
705-647-6886

Medichair Thunderbay

977 Alloy Drive, Unit 7
Thunder Bay, ON P7B 5Z8
807-623-9110

Q Northend Mobility

301 Aqueduct St.
Welland, ON L3C 1C9
905-735-5552
1,2

Shopper Home Healthcare

202 Sparks Ave.
Toronto, ON M2H 2S4
416-701-1351

Shoppers Home Healthcare

2028 Dundas Street East
London, ON N5V 1R2
519-455-4488

Q Sparrow Hawk Industries, Ltd.
675A Davenport Rd
Waterloo, ON N2V 2E2
519-884-4295
1,2,3

Q Universal Motion
120 St. Regis Crescent South
Toronto, ON M3J 1Y8
416-398-4255
1,2,3

QUEBEC

Centre Auto de Duberger, Inc.
2957 Blvd Pere Lelievre
Quebec, QC G1P 2X9
418-683-4876

Centre d' Autonomie
399 Ave De La Friche
Dolbeau-Mistassini, QC G8L 2T3
418-276-8336

Q Centre de L'auto St-Lambert
145 Damase-Breton
St-Lambert-de-Lauzon, QC
G0S 2W0
866-641-0419
1,3

Handi-Service XSRP, Inc.
3640 Richelieu
St. Hubert, QC J3Y 7B1
866-464-2634

SMVR 2 Visions, Inc.
414, boul. St-Germain Ouest
Rimouski, QC G5L 3N4
418-723-9225

Q TVR Technologies, Inc.
595 Lanaudiere
Repentigny, QC J6A 7N1
888-919-2555
1,2,3

Van Action
4870 Rue Courval Ville
St-Laurent, QC H4T 1L1
800-668-8705

SASKATCHEWAN

Medichair Regina
3033 Saskatchewan Drive
Regina, SK S4T 1H5
306-584-8456

INTERNATIONAL

UNITED KINGDOM

Adaptacar Mobility Specialists
Pathfield Business Park
South Malton, Devon EX363LH
01769-572785

QAP SCORECARD

TOTALS FOR DEC 2011 - FEB 2012

**TOTAL QAP MEMBERS
IN GOOD STANDING:**

267

New Applications:	14
Initial Accreditations:	11
Suspensions:	5
Reinstated:	1



CEO'S REPORT

DAVE HUBBARD (NMEDA CEO/EXECUTIVE DIRECTOR)

Previously with ShowMax Marketing in California, Dave Hubbard took over the position of Chief Executive Officer for The National Mobility Equipment Dealers Association (NMEDA) during the summer of 2008. Dave's 28-year career includes working in Detroit in brand marketing for automotive manufacturers as well as advertising agencies. Concerns or questions for Dave may be directed to him at info@nmeda.org.

Getting Ready For the Next Fiscal Year

Much As we approach the end of NMEDA's fiscal year, June 30th, planning for next year starting July 1 is well underway. While the final business plan for the year is still being written, many of the departmental plans are in place and I would like to provide you with an overview of where we are heading.

Before the marketing plans can be developed, the IPR Committee will be evaluating the results of National Mobility Awareness Month (NMAM). The primary goal will be to determine on what level the promotion worked well and in what areas can it be improved. Sub-committees are being formed to examine all aspects of the program. This would include all the communications issues, such as did the program deliver the message we wanted to convey? That message included increasing awareness for automotive mobility solutions and increasing the knowledge of what is available and where to find them: Namely, your local NMEDA mobility dealer. With the website traffic numbers reaching into the millions, it is

fairly obvious that we created a great deal of "awareness." The question now is what kind of awareness? Promoting what it means for a consumer to choose a NMEDA dealer over a non-member is paramount.

To help answer these questions a "pre and post" awareness study was put into place as a major evaluation tool for the program. The first wave of the study was conducted in February just prior to the program launch at the 2012 NMEDA Conference. The second wave, the "post" study, was fielded in mid June. This is an online study designed to ask questions about a person's knowledge of mobility solutions, their awareness of dealers who sell these solutions, awareness of NMAM, NMEDA and the major sponsors. The questions in phase I are nearly identical to those in phase II so that they can be compared in order to determine the level of increased awareness in the various areas surveyed.

In addition to the research, the IPR committee will be evaluating the technical aspect of the program, particularly the contest website. There is no question there were some problems with the site design, however, these is-

issues were ultimately resolved and the contest finished in grand style. In general, the public seemed very pleased with the contest and all the residual benefits it brought to the party, besides just being a contest. (See Contest feedback on page ____). The real question is how we can fix it so we never face that down time issue again, if in fact, we decide to continue the program next year?

These are more than a few of the questions being reviewed by the IPR program evaluators and it is our intent to make their findings available to you in the August membership meetings if not before.

Under Education and Training, a plan is already in place that will provide our membership with continued training support and grassroots marketing by way of education programs for related healthcare fields. One of the newest projects to be taken up by NMEDA is "technician certification." NMEDA's training programs have grown over the last three years to include a number of online and hands-on training initiatives. It is the Education and Training Committees opinion that we now have enough of a training base to develop a technician certification

program similar to those offered in the related automotive and RV fields. Initially the program would be voluntary any tech who engages and passed the test would have a certification as one of the highest recognitions of competence in our industry. Most of the elements of the certification are already required in some form either by NMEDA or member manufacturers as part of their product qualification. It is now just a question of organizing the various elements into a single unit and testing for overall competency. I believe this is something the industry needs and now is the time to develop and implement it.

In addition, the Education and Training Committee has been working on a “pay for performance” hypothesis. This is based on the webinars presented under the Professional Business Series banner that included guest speaker Cecil Bullard. Studies done in the automotive arena have shown that technicians could be spending as little as 30% of their time being productive in the area of paying service jobs or billable hours. This means that the dealership is only getting a 30% return on its employee investment. In theory, we assume this to be true in the mobility industry as well and have developed a program that would reward a technician based on the work completed and billed. The greater the billing: The greater the reward. This would also mean increased profits for the dealership.

By combining the Pay for Performance scenario with the Certification, it is anticipated that the higher level of knowledge will produce greater more efficient performance, thus increasing wages earned and business profits.

This study should take about a year to complete and should be very interesting reading.

The Board and some of the membership have determined that the National Conference needs to be shaken up a bit in the name of keeping it interesting for all the attendees. To that end, the Conference Committee has been busy sending out membership surveys and meeting on the results in an effort to provide the membership with a Conference more in tune with their needs and wants. The conferences of the past few years have been very successful for NMEDA despite the weak economy. However, changing up the action to make it more interesting and more in line with today's needs is an exciting prospect. Some of the ideas being explored are manufacturer presentation in lieu of standard type workshops, opening the exhibit hall to the public and offering more business improvement workshops that have more to do with systems and process design to make our businesses more efficient and, in theory, more profitable. Planning a conference is no easy task under the best of circumstances, and trying to do it while building in change in order to increase performance is challenging, indeed. I believe the Committee is up to it and I know the NMEDA staff can deliver the goods. See you next February and prepare to be engaged.

The Government Relations Committees are very active these days both in Washington DC and in New York State. We are about to embark on our third visit to the nation's capitol in an effort to get the attention of Legislators

and the VA in order to instill a set of criteria for the VA facilities to select mobility dealers. This is in addition to trying to shake loose the VA Automotive Handbook that seems to be hung up in the regulatory process.

In the meantime, New York dealers are getting closer to being legally licensed under the state's franchise laws. There is a question of whether or not it will happen this year, but I am confident that it will happen eventually. The Committee has been working diligently to gain support from the various political camps including the Governor's office. Many thanks to Paul Tobin of the United Spinal Association for his support and guidance based on his experience and knowledge of the NY legislative system.

All other committees are in full swing now that we have gotten through the startup period that seems to follow the conference each year. I am proud to say that all our committees are being productive and you can look forward to another strong year at NMEDA. As always, if you have any questions about what is going on at NMEDA, any concerns, or just have an idea we should look into, please don't hesitate to call or email me. Have a great summer and good selling!

Last word: I would just like to give a huge “Thank You” to all the sponsors of National Mobility Awareness Month, specially our major sponsors. To Chrysler, SanTan Honda, and Toyota Motor Sales who so generously provided the minivans - Thanks you! Also, To BraunAbility and VMI who provided the lowered floor conversions - Thank You!



One World. One Cause. T

National Mobility Awareness Month is a celebration that encourages people with disabilities to enjoy active, mobile lifestyles. Based on the enormous feedback and positive messages we've received regarding the promotion, it also motivated people to speak up and out about all the friends, neighbors and loved ones in their lives who are overcoming challenges and disabilities every single day.

In magazines, newspapers and all across the web people took the cause to heart, writing and posting in support of NMEDA and their sponsorship of the celebration. From Facebook to Digg to Twitter to Tumblr to Pinterest and Craigslist, the community came together to express their feelings and get behind this important cause.

HERE ARE SOME OF THE THINGS THEY HAD TO SAY:



Lynn Frazier We are so grateful as well. The average income in our community is \$13,000. But this contest brought HOPE to so many who had given up on magical possibilities. Alberto and his family followed #AlbertoDream on FB and saw daily, a show of support and love from friends, family, schools and businesses in our town. None of this would have happened without your contest as reason to bring people together for the possibility of a miracle. Thank you so much!
5 hours ago via mobile · Unlike · 1



Cha Smythunwesn I hope everyone realizes that it would have been wonderful enough to give away one van but NMEDA opted to give away three. Those three gifts will be appreciated by whomever they have chosen and I cannot even begin to comprehend what a difficult job they had in choosing the three winners! Congrats to those who have won, and for those who did not, hopefully there will be a "next" year. Thank you to NMEDA to having this contest in the first place.... :)
9 hours ago · Unlike · 3



Thousands of Supportive Voices.

National Mobility Equipment Dealers Association | Life Moving Forward



Karen Siciliano Congrats to the winners and thank you for this amazing opportunity we were given. We won because we were overwhelmed with support and love and votes daily by our friends and family. SO that makes us a winner. I'm very happy for the 3 winners.
12 hours ago · Unlike · 4

Rebecca Stinnett Maas I just wanted to say thanks. I love that with this contest we have been able to show everyone how absolutely rewarding it can be to parent a child with a disability. Our son is a complete joy and I love being able to share his joy with others.
about an hour ago · Unlike · 2

Tammy Dudley Because of you NMEDA you have raised awareness for the need of these vehicles, I knew we were not alone in this need but had no idea so many! Thank you for the opportunity! We are now organizing a fund raiser to buy a used car and without this contest we would of never had the Fan base to do something like this! Thank you and congratulations to the 3 very deserving and blessed families!

Instead of being angry you didn't win take that energy and focus on getting what you need! If you can pull in 50 & 70 thousand votes you can raise enough for a used one! We found a 2003 Honda with 60,000 miles and only need to raise 3,500\$ for it!!!
Yesterday at 2:42pm via mobile · Unlike · 6

Celia A. Brewer
NMEDA: I want to recognize you for sponsoring the Local Heroes Contest. The stories are both heartwarming and heartbreaking. The contest illuminates a great need in this country and has put the spotlight on an often silent population. Further, the contest is doing precisely what it intended: teaching the community that mobility and accessibility mean freedom for those with physical limitations. Thank you from the bottom of my heart.
Unlike · Comment · 6 hours ago near Cardiff-by-the-Sea, CA

You and Doan Hohmeyer like this.

National Mobility Equipment Dealers Association (NMEDA)
Thanks for your support Celia!
5 hours ago · Like · 1

Celia A. Brewer I just didn't want you to think the big picture theme was lost in the heat of competition. And the competition is hot! My fingers are raw from typing vote requests, but the underlying message is the most important one. Thank you again.
5 hours ago · Like · 1



MobilityAwarenessMonth.com
866.948.8341



Inaugural National Mobility Awareness Month Local Heroes Announced

On June 8, 2012, the winners of the National Mobility Awareness Month Local Heroes program were announced on the syndicated morning television show, “The Daily Buzz”. Alberto Cruz (Willimantic, Conn.), Ken Davert (Bay City, Mich.) and Ron Miner (Frankfort, Ill.), shared stories of triumph overcoming their disabilities and how their new, wheelchair accessible vehicles will further empower them in their active lifestyles.

valued at approximately \$40,000 - \$80,000 each, later this summer.

The contest welcomed more than 1,700 Local Heroes entries and 1.2 million votes were cast at the MobilityAwarenessMonth.com website. “We are humbled by the response to the National Mobility Awareness Month Local Heroes program,” said Dave Hubbard, executive director and CEO for NMEDA. “This enthusiasm clearly illustrates the need for custom-built transportation and it is our com-

mitment to advance the awareness month’s efforts in the future with the generous support of the membership, sponsors and public officials.” Continued Hubbard, “Moreover, it’s an honor to award the wheelchair accessible vehicles to these inspiring individuals. Alberto, Ken and Ron possess the conviction to make their mark by focusing on their education, supporting veterans and advocating for those with disabilities, and simply motivating those around them. It has been exciting to watch their family, friends and neighbors rally around their Local Heroes.”

Leaders in Washington, D.C. have also taken notice of the awareness month. Recently, on the floor of the U.S. House of Representatives, a resolution was submitted to designate May 2012 as National Mobility Awareness Month. “It is an honor to receive this support,” commented Hubbard. “Thank you to Congressman John Barrow (Ga.-12) for making this educational effort a priority.”

“The contest welcomed more than 1,700 Local Heroes entries and 1.2 million votes were cast...”

In its inaugural year, the National Mobility Awareness Month has one message: “Life Moving Forward.” The effort alerts seniors, veterans and people with disabilities across the United States and Canada about the variety of mobility options available to them.

As part of this initiative, program champion, the National Mobility Equipment Dealers Association (NMEDA), created an online contest to award three individuals with customized wheelchair accessible vehicles. Sponsors Toyota, SanTan Honda in Chandler, Ariz. and Chrysler, came together to provide the vehicles, which will now be modified by NMEDA member manufacturers – BraunAbility and Vantage Mobility International. Cruz, Davert and Miner will take ownership of their vans,



On June 8, 2012, the winners of the National Mobility Awareness Month Local Heroes program were announced on the syndicated morning television show, “The Daily Buzz”.

Meet the Local Heroes Winners:

- **Alberto Cruz**

Last summer, the 15 year-old became paralyzed while surfing on Narragansett Beach, R.I. Despite grueling therapy sessions after the accident, Cruz chose to continue his schooling and remain connected with his community. This moved his teacher, Lynn Frazier, who nominated him as a Local Hero. "Heroes attract other heroes. Alberto's courage touched something deep inside my students and their families," said Frazier. "It planted a seed of hope in our community."



Alberto Cruz

- **Ken Davert**

Managing his own cerebral palsy, the Davert family is also coping with wife, Missy's and their 13 year-old twins, Austin and Michaela's, osteogenesis imperfecta (a brittle bone condition). The family is active in their community from Michaela in Girl Scouts to Missy as a life-long advocate for people with disabilities.

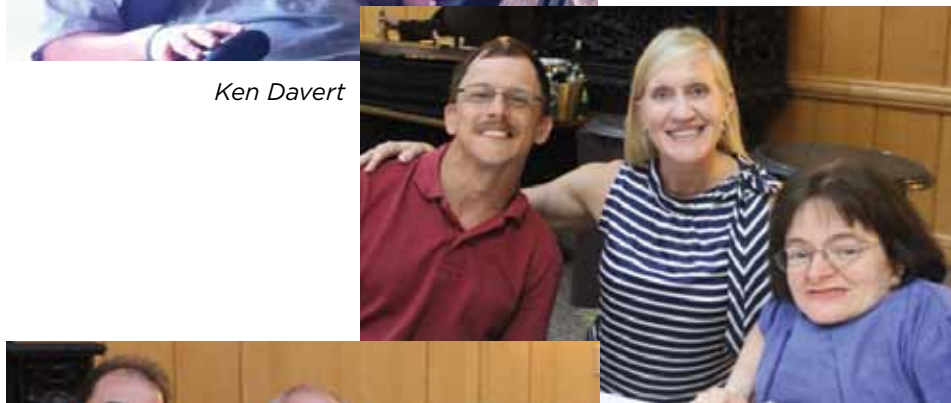

Ken Davert

- **Ron Miner**

Miner is a disabled, U.S. Army veteran who was injured during active duty. After the incident, he became depressed. However, upon hearing about a wheelchair bodybuilding competition, he resolved to turn his life around. With intense training, he became a Wheelchair Bodybuilding Champion and won numerous gold medals at the National Veterans Wheelchair Games. Today, he is an activist for those with disabilities.



Ron Miner

Also appearing on The Daily Buzz:

Sam Cook, president of both the NMEDA Board of Directors and of Superior Van & Mobility based in Louisville, Ky., and national spokesman, Mike Savicki. A C6, 7 quadriplegic; veteran; athlete; and entrepreneur, Savicki is a passionate advocate of efforts such as National Mobility Awareness Month. The Daily Buzz reaches more than 84 million television households within the U.S. each weekday morning.

About National Mobility Awareness Month:

National Mobility Awareness Month is the inaugural May celebration that encourages people with disabilities to enjoy active, mobile lifestyles. Founded in 1989 as a non-profit trade association, the National Mobility Equipment Dealers Association (NMEDA) supports the awareness month with the assistance of more than 600 mobility equipment dealers, manufacturers and driver rehabilitation specialists dedicated to expanding opportunities for people with disabilities.

For updates, please visit NMEDA's Facebook, Twitter or website.

“ On the floor of the U.S. House of Representatives, a resolution was submitted to designate May 2012 as National Mobility Awareness Month...”

Join Us for a Webinar!

Dealer Marketing Webinar #9:
Back to Basics for Successful Sales

July 24, 2012 @ 1pm EST

July 26, 2012 @ 1pm EST

With guest expert Fleming Ford (SHOREforce) on how to recruit, grow and accelerate a successful sales team.

Register for this and other future webinars by visiting <http://members.nmeda.org/members/membership-resources/>. You will need to log in to access the link.

You may also view our past webinar materials by visiting the NMEDA Member site. PDF and video files are available in our complete webinar archive.

Canada Dealers Need to Start Purchasing QAP Labels from NMEDA

As part of the Canadian audit transition to NMEDA, Canadian dealers will need to begin purchasing Quality Assurance Program (QAP) labels directly from NMEDA. Starting July 1st, all Canadian dealers need to start applying the new QAP label to installations and cease using the current RADCO QAP label.

All unused RADCO QAP labels must be returned to NMEDA, and will be exchanged for equal quantity of the

new NMEDA Canadian label.

If you have any questions relating to this new label system, please call the NMEDA office for further clarification. We are more than happy to thoroughly explain this new process to our members.

New Online Resources Available: FREE for NMEDA Members!

Make Inoperative Training Module: In response to Dealer member requests we have put together a free online resource for you: The Make Inoperative Module (MIM). This 20-minute online course will help you better

understand NHTSA Make Inoperative Exemption regulations and paperwork requirements.

QAP 1-2-3 Online Training: NMEDA provides QAP 1-2-3 courses free to all Dealer members upon request. An official 2-year hard copy certificate is available for QAP-3 Guidelines Training as a stand-alone unit or for QAP 1-2-3 as a bundled course. Please specify if you want to take the courses for credit (certificate) or audit only. For-credit courses with certificates require that you set up a free Ignite-cast account and successfully pass cumulative quizzes through out the training. (Accredited by ADED for 3 contact hours.)

Expand Your Reach With OTs & PTs

According to research, the majority of your customers consult with health professionals prior to purchasing a vehicle or mobility equipment. For this reason, we have developed a simple course that can be presented by you to assist in reaching out to local "influencers".

Don't miss out on this valuable (and free!) opportunity to potentially be the first to provide this program to OTs and PTs in your state or region!

The course is designed to be conducted in a short

"Lunch Meeting" format. It will not only benefit health professionals (by providing them with 1 AOTA* contact hour and informing them about available equipment options), it is also an ideal way to promote your business to the parties who may have the greatest influence on your customers.

To learn more about this exclusive opportunity and about becoming an instructor, contact Pete Lucas at (800) 833-0427 or email pete@nmeda.org today!

* 1 Contact Hour = .1 CEU. The assignment of AOTA CEUs does not imply endorsement of specific course content, products, or clinical procedures by AOTA.



Follow us!

Facebook: Look for "National Mobility Equipment Dealers Association (NMEDA)"

Twitter: @NMEDAcem (<http://twitter.com/#!/NMEDAcem>)

NMEDA Third Quarter Finance Report

As of January 2012 the NMEDA Board of Directors agreed that it would be in the best interest of the organization to share NMEDA finance information on a Quarterly basis. Shown here is the 3rd Quarter* Balance Sheet and the Quarterly Income and Expense Report that has been reviewed by both the Finance Committee and the Board. If you have any questions regarding these figures please contact Dave Hubbard in the NMEDA office at 800-833-0427 or send an email to info@nmeda.org. (Bill Koeblitz - NMEDA Treasurer) *3rd Quarter of NMEDA fiscal year beginning July 1, 2011

2012 3rd Quarter Balance Sheet

ASSETS	Mar 31, 12
Current Assets	
Checking/Savings	\$ 887,506.22
Accounts Receivable	\$ 81,927.50
Other Current Assets	\$ 11,263.00
Total Current Assets	\$ 980,696.72
Fixed Assets	\$ 451,716.43
TOTAL ASSETS	\$ 1,473,412.15
LIABILITIES & EQUITY	
Liabilities	
Current Liabilities	
Accounts Payable	\$ 55,403.25
Other Current Liabilities	\$ 12,534.72
Total Current Liabilities	\$ 67,937.97
Long Term Liabilities	\$ 243,422.01
Total Liabilities	\$ 311,359.98
Equity	\$ 1,121,053.17
TOTAL LIABILITIES & EQUITY	\$ 1,432,413.15

2012 3rd Quarter Income and Expense Report

Income	Jan - Mar 12
Net Income	
Circuit Breaker	\$ 12,836.27
Conference- Net Result	\$ 35,944.55
Member Benefits	1,363.02
Membership Dues	158,730.00
QAP Program	7,473.06
Education & Training	12,960.15
Total Income	\$ 229,307.05
Expense	
Committee & Board Expenses	6,614.45
Depreciation Expense	4,749.00
Insurance	21,177.67
Office Expenses	27,599.50
Payroll Expenses	142,685.00
Marketing Program - Net Results	\$ 45,092.57
Total Expense	\$ 247,918.19
Net Income	\$ (18,611.14)



Like peas and carrots, it just **makes sense.**

Always look to your fellow NMEDA members first when buying and selling automotive mobility products and services. As NMEDA members we all adhere to the NMEDA Guidelines helping to ensure the best possible business outcomes.

It just makes sense...

NMEDA members support NMEDA members.

For a complete list of NMEDA members, visit www.nmeda.com.



NMEDA Hall of Fame 2013: Call for Nominations

There is any number of people working within and around our Association, now and in the past, who would be deserving of the NMEDA Hall of Fame. It's time once again time to begin the selection process to find next year's Hall of Fame inductees. Since there are only a limited number of slots open each year it is important that resubmit any previous nominations for consideration. If you thought about doing it last year and just didn't get to it, now is the time to start. We would like your nominations as soon as possible. Make the effort to recognize those who have made a significant contribution to supplying freedom and independence to so many special people.

“ It's time once again time to begin the selection process to find next year's Hall of Fame inductees...”

Pick the Category in which you are nominating a person. Include in the narrative why you think this individual belongs in the NMEDA Hall of Fame and what significant contributions they have made to the Automotive Mobility Industry. Tell us where and during what time frame they were active and what their current status is in the industry today. This person(s) is not necessarily required to have been a NMEDA member and you can nominate more than one person. Also, keep in mind that just because a person is nominated doesn't guarantee admittance to the Hall of Fame. If they are not chosen one year they can be re-nominated in subsequent years.

NMEDA Hall of Fame - Dealer Criteria

1. To be eligible for the NMEDA Hall of Fame, a candidate must have served at least 10 years in the Automotive Mobility Industry. More specifically the candidate must have served in the capacity of providing services to people with disabilities.
2. Any individual becomes eligible for nomination to the Hall of Fame if they are or have been active in and/or made a contribution to the automotive mobility industry.
3. A candidate for the NMEDA Hall of Fame must have been well known in the industry and would have been recognized as an industry leader by their peers.
4. A candidate for the NMEDA Hall of Fame would have been an

innovator and trend setter in automotive mobility industry, and would have had a direct and significant impact on the industry. Evidence of this legacy and the significance of its impact must be chronicled in the nomination form.

5. A candidate must receive a minimum affirmative vote of 60% (5 out of 7) of the members of the NMEDA Hall of Fame Committee.

Hall of Fame Criteria - Allied Categories

1. Individuals who are allied to the automotive mobility industry - specifically manufacturers, driving

rehabilitation specialists, related health care fields and government personnel working with rehabilitation services, among others - can also become candidates for the NMEDA Hall of Fame.

2. An individual becomes eligible for nomination to the Hall of Fame who has been, or is currently, active in the automotive mobility industry.
3. A candidate for the NMEDA Hall of Fame must have been well known in the automotive mobility industry and would have been recognized as an industry leader.
4. A candidate for the NMEDA Hall of Fame will have been an innovator and trend setter in their respective field of endeavor and would have had a direct and significant positive impact on the automotive mobility industry. Evidence of this legacy and the significance of its impact must be chronicled in the nomination form.
5. A candidate must receive a minimum affirmative vote of 60% (5 out of 7) of the members of the NMEDA Hall of Fame Committee.

Selection Limitations

1. No more than three individuals meeting the criteria for membership in the Hall of Fame (dealer category) will be selected to the Hall of Fame in a single year with the exception of the first two years, where the maximum per year will be five. No more than one person meeting the criteria for Hall of Fame (Allied Category) will be selected per year with the exception of the first two years, where the maximum per year will be two.

2. There is no limit to the number of times a person may be considered for the Hall of Fame.
3. There is no lower limit to the number of inductees that must be selected.

Nomination Process

1. Anyone in the automotive mobility industry may submit nominations to the NMEDA Executive Director.
2. In order to be eligible for nomination, a Hall of Fame nomination form must be completed and returned to the Executive Director, or a member of the Hall of Fame Sub-Committee. These forms may be secured by request or on the NMEDA website.

Announcement and Recognition of Inductees

1. The announcement of those selected for induction into the Hall of Fame shall be made in a special release to the Mobility news media by the Executive Director.
2. All selections will be presented at the NMEDA Annual Conference.

Hall of Fame Sub-Committee

The NMEDA Hall of Fame Sub-Committee will be comprised of at least 7 members. These members will review nominations as they are received.

The Hall of Fame Sub-committee will be comprised of:

- One Board Member - Dealer
- One dealer member from the Membership Committee
- Two additional Dealer Members
- Two Manufacturer members
- One Associate members

Hall of Fame Sub-Committee members will serve a term of two years with three rotating off after the first year and four rotating off after the second year. This respective rotation pattern will continue every year thereafter (three members one year - four members the next).

The Hall of Fame Nominations Form is Located on Page 28.

The 2012/13 Hall of Fame Committee Members are:

Bob Nunn - Chairperson
 Bill Siebert - Board Member
 Doug Eaton
 Mark Whitehouse
 Marc Sagal
 Catherine Martin
 Gene Morton

“ Anyone in the automotive mobility industry may submit nominations to the NMEDA Executive Director....”

NO LIMITS_{L & S Inc.}
BATTERY SAVER

With the addition of mobility equipment, such as lifts, and interlocks (required by FMVSS 403), the demands on your vehicle's battery can discharge it in a matter of days! Return your vehicle to the FACTORY level of current draw each time you lock the door with the FACTORY remote or internal door lock switch. Each time you unlock your door, the equipment is immediately powered up.

Call (530) 514-1825 to locate a Dealer near you.



Call for specific vehicle applications.

For Information contact:
NO LIMITS_{L&S INC.}
 P.O. Box 7295
 Chico, CA. 95927-7295
www.nolimitslinc.com

Phone (530) 514-1825 or Fax: (530) 343-3897

VMI Announces Online Wheelchair Lift Application Guide

The Valet Plus, an innovative and luxurious automotive seat for individuals who have difficulty getting into and out of today's higher vehicles, has been introduced by Vantage Mobility International (VMI), a leader in the manufacture and distribution of wheelchair accessible full-size and minivan conversions, announced that the company has launched an online guide that

can help customers select the best wheelchair lift for their vehicle, needs and budget. The VMI Wheelchair Lift Application Guide is the first online tool of its kind in the industry and was launched at <http://lag.vantage-mobility.com/>.

"I'm excited that VMI is offering such a robust, online tool for new customers and our dealers," said Doug Eaton, president of VMI. "There are a lot of variables that buyers have to consider when choosing the best wheelchair lift for their specific needs. That's why we populated our Wheelchair Lift Application Guide to be completely comprehensive. Not only will the guide help direct a customer to the best platform lift for their needs, it will also show local, authorized dealers who can provide a professional installation."

“ VMI is offering a robust online tool for new customers and our dealers...”



The online resource is a simple-to-follow questionnaire that methodically and intuitively guides customers through the platform selection process, which includes selecting:

- Vehicle make (Chevrolet, GMC, Mercedes-Benz, Dodge and Ford)
- Model year (2001 to present, depending on the make and model of the vehicle)
- Lift location on the vehicle (rear or side)
- Raised roof and lowered floor
- Wheelchair weight, length and width

Once complete, the Guide will generate a list of viable wheelchair lift options that include important purchasing factors including price, reliability, road noise, interior access, driver's unobstructed view and front passenger seat use.

"We know that people turn to the Internet when they need to research and buy mobility products," said Tim Wong, product manager at VMI. "Our Wheelchair Lift Application Guide is another great example of how VMI is becoming the ultimate resource of information, technology, products and services for our customers and dealers. Our guide will empower our customers with the kind of information that'll make it easier for them to buy the right platform lift for their needs and budget."

The online resource is a simple-to-follow questionnaire that methodically and intuitively guides customers through the platform selection process.



NATIONAL MOBILITY
EQUIPMENT DEALERS
ASSOCIATION

NATIONAL MOBILITY EQUIPMENT DEALERS ASSOCIATION

SUPPLY ORDER FORM

To purchase the items below, fill out the order form and fax it to NMEDA at 813-962-8970. An invoice with the amount of purchase and shipping charges will be sent along with the order.

Item	Price	Qty	Total
Consumer Reference Guide to Purchasing Adaptive Vehicles and Equipment: United States Version	.50		
Canadian Version (Includes Français Translation) ***Pack of 20 Guides***	20.00		
NMEDA Dealership Promotional/Showroom Brochure "Look for This Symbol!"	.20		
NHTSA - Make Inoperative Labels	.25		
Tire Placard Labels	.50		
Load Carrying Capacity Labels	.50		
Wheelchair Logo Pin	2.50		
NMEDA Logo Sticker (2 per sheet)	Set - 5.00		
NMEDA Average Price Survey (Conducted in 2011)	50.00		
QAP Logo Sticker	1.50		

Special Instructions / Comments

TOTAL: _____

Shipment Information

Contact Person: _____

Business Name: _____

Address: _____ City: _____ State: _____ Zip _____

Ph: (____) _____ Fax: (____) _____ E-mail: _____

Fax or mail completed form to:
 NMEDA, 3327 W. Bearss Ave. Tampa, FL 33618
 FAX: 813-962-8970, PH 800-833-0427 www.nmeda.com

04/06/12

NMEDA Contact Information Audit

In an effort to improve NMEDA membership communications, we would like to reconfirm your contact information currently in our database, make any corrections required and add additional contacts based on job discipline (sales, technical and administration). You may add as many or as few contacts as you want.

Designated Rep (as noted on application or update here):

- Same as on record Change to: _____ Email: _____
 Would like to receive all NMEDA Communications

Owner (voting member with fiscal responsibility, as noted on application or update here):

- Same as above Change to: _____ Email: _____
 Would like to receive all NMEDA Communications
 Would like to receive only critical communications (voting, QAP status, etc.)

Sales Contacts: (optional)

Name: _____ Email: _____ Phone: _____
Name: _____ Email: _____ Phone: _____
Name: _____ Email: _____ Phone: _____
Name: _____ Email: _____ Phone: _____

Technical Contacts: (optional)

Name: _____ Email: _____ Phone: _____
Name: _____ Email: _____ Phone: _____
Name: _____ Email: _____ Phone: _____
Name: _____ Email: _____ Phone: _____

Administration Contacts: (optional)

Name: _____ Email: _____ Phone: _____
Name: _____ Email: _____ Phone: _____
Name: _____ Email: _____ Phone: _____
Name: _____ Email: _____ Phone: _____

It is NMEDA's intent to direct all communications to the Primary and/or NMEDA Member contacts as directed, and provide relevant information to the sub-groups (i.e. Sales Training information to sales personnel, Technical Bulletins to technicians, etc.). To add additional people to the contact list, simply place their name, email address and direct line on a separate sheet and fax it to NMEDA.

Please also provide the following:

Your Name: _____ Company Name: _____
City: _____ State: _____ Phone: _____

THE ORIGINAL

We're celebrating 25 years!

Here at EZ Lock, we've been providing confidence and security for wheelchair seated drivers and passengers for a quarter of a century.

Back in 1987, we were the first to introduce a system that enables anybody who relies on a wheelchair, to safely and easily drive or ride in an Adaptive vehicle. Today, we're still number one thanks to the many thousands of happy customers whose lives the EZ Lock system was able to improve through the freedom of mobility.

Without you, we would not be where we are today and we look forward to serving you for many more years.



EZ LOCK

WHEELCHAIR DOCKING SYSTEMS

★ 25th ANNIVERSARY ★

PATENTED IN 1987

Thank You!

Talk to us:

888-952-5625

Fax: 866-297-1320

Find us online: ezlock.net

We've got the **LOCK** on safety.



NOW ON TOUR

QLK-150

WITH VERY SPECIAL GUEST

DIOR

DRIVE-IN OCCUPANT RESTRAINT

ARE YOU READY TO DOCK?

FEATURING:

EXTENSIVELY CRASH TESTED ★ SLIM & FLEXIBLE DASH CONTROL ★ REDUCED FOOTPRINT
SMART (ECM) ★ OVER-TORQUE PROTECTION ★ HEAT-TREATMENT ★ REMOVABLE COVER

AND SMASH HITS:

WE WILL...DOCK YOU! ★ FOR THOSE ABOUT TO DOCK ★ DOCKIN' IN THE FREE WORLD



GET ALL THE GREATEST HITS, RAIN OR SHINE AT: Q'STRAIT.COM

YOU SHOULD HAVE BEEN THERE

In case you missed it, here's a recap of our recent webinar on Social Media 2.0.

National Mobility Equipment Dealers Association | **Driving Independence**

Social Media 2.0

Gone are the days when a social media strategy was optional. Social media has become so entrenched in the lives of consumers and businesses alike that in-house teams dedicated to social media have become commonplace, and social media has extended beyond marketing and into other departments and areas such as recruitment and sales. Social media is an essential discipline – not just an option.

2012 Predictions and Benefits

Predictions

- Sharing on Facebook will grow exponentially. Users will double the amount they share each year.
- Better tracking metrics will value content based on how often it's shared and the impact of those shares.
- YouTube is poised to disrupt the television landscape with premium programming and the design of user experience for the small screen.
- Second tier, personalized networks will become mainstream and offer a more curated experience for users.

Benefits

- Team members intuitively know how to represent the brand in all circumstances.
- 24/7 consumer engagement.
- Risk reduction if something goes awry with your brand.
- Increase in revenue.



Social Media Options

Despite the large number of social media options available, it makes good sense to focus your efforts in a few key areas. Concentrate on Facebook, Blogging and Twitter. How to Engage Fans on Facebook:

- Post regularly, use pictures and upload videos worth sharing.
- Ask for your fans' opinions.
- Run a Poll using the "Ask a Question" feature.
- Try posting "fill in the blank" posts.
- Give fans access to exclusive information and reward them with deals or perks.
- Geotarget your posts for location specific content.

Keys to Business Blogging

- Keep your blog updated with fresh, timely and engaging content to bring your audience back for more.
- Use a wide variety of content inclusive of search results, rich posts, leadership thoughts and customer user stories.
- Ask customers to share their stories. Those who solicit customer stories get a higher click-thru than those who don't.
- Create an editorial calendar and stick to it.

Twitter Best Practices

- Tweet multiple times a day to continually show up in followers' feeds.
- Integrate branded hashtags for your business.
- Integrate strategic hashtags to show up in trending topics' feeds.
- Retweet useful content.
- Don't follow more than double the amount of people following you.





14 Step Plan

1. Identify the personas of your audience.
2. Develop content that speaks to the pain points of each persona.
3. Identify sources of content in your organization.
4. Develop content for each stage of your customer's lifecycle.
5. Create an editorial calendar of your content plan.
6. Assign content production to as many people as possible.
7. Develop a diversified portfolio of content across different platforms.
8. Leverage social media as engagement channels.
9. Define success metrics & measure impact of your strategy.
10. Gain c-level support.
11. Produce content that has sales impact.
12. Focus on the 4 E's - educate, entertain, enlighten and engagement.
13. Experiment with your content.
14. Study content marketing in & outside your industry for new ideas.



Inbound Strategy

Three quarters of people believe that advertisers lie. However, social media works because people do trust recommendations and information from friends, other people, company websites, editorials and brand sponsorships.

Content Strategy

It's important to understand your audience and focus your content on them. Know who are the decision makers, influencers, promoters and end users. Identify their wants and be relevant to them. Keep things fresh and constantly test new ideas.

Tips and Trends

Know your target audience and understand what they care about: Seniors, Caregivers, Baby Boomers, Veterans, Local Organizations, etc. You also need to focus on the right platforms where your audience can be found and consider what hardware they're using. For example, are they using smart phones or tablets?

- The average website integrated with Facebook will see a 300% increase in referral traffic.
- One of every six minutes spent online is on a social network.
- 48% of consumers combine social media and search engines in their buying process.
- Facebook and YouTube claim the majority of ad spending.
- Blogging and YouTube help improve SEO results. Did you realize YouTube is the #2 search engine?



Stay tuned for our upcoming webinars where we will cover items such as search engine marketing, event marketing and making promotions work for you.

NMEDA.com • 866.948.8341

ATTENTION ALL TECHNICIANS

NMEDA wants to hear about the topics that are important to you to put in our Technician's Corner!

We want to write about the most relevant issues that technicians in the mobility industry face every day and share the most innovative ideas you have in our publication. After all, we all have a common goal of serving our clients and providing a great customer experience.

A new group on LinkedIn has been created exclusively for NMEDA technicians. We encourage ALL technicians to join and start some discussions, post questions or comments, and contribute to the success of our industry.

At your earliest convenience please send an email to ray.morton@mobilityworks.com and make a request to join OUR group; you'll be glad you did!

In addition, another tool is in place as a way for technicians to communicate with one another to discuss product issues, ideas, things that are happening in common that can save everyone a lot of time, energy, and money. Let's learn to work smarter not harder

NMEDA's Technician Group is an online environment for discussing items related to a specific subject; lowered floor minivans, securement issues, make inoperative exemption, understanding weighing vehicles, etc. This group can contain multiple topics as well. Topics are different discussions related to the group's subject. Topics in a group about mini vans might be



battery drain, kneel system failure, adding seating etc. Topics can contain multiple posts. Posts are replies from readers to the topic.

Following are some things you can do with the NMEDA Technician Group:

- Engage in discussions about a specific subject.
- Create a question and answer support group for a product, service, process your company is using.
- Find people with similar issues on a subject or topic that may help you resolve a problem, prevent a problem, or increase customer satisfaction.
- Read group posts through email, the online interface, or both.

The bigger this group gets, and the faster it grows means we can all benefit from the information posted. It means more professional and efficient technicians for our industry!

As an example, there is a lot of discussion lately on making the service department more profitable. Some ideas

include performing general automotive and service and incentive pay based on efficiency. Other technicians want to know what you're thinking. Let your voice be heard.

A fellow technician at another mobility dealership is going through the same thing you are. There are many common situations we are all dealing with on an individual basis. Let's not waste valuable time and resources trying to resolve the same things in each of our own shops. Let's share our experiences and make everyone's life easier.

Please send a message to the group's email: nmeda-technician-corner@googlegroups.com or to ray.morton@mobilityworks.com to have an invitation sent to join the group.

You can also visit this group on the web at <http://groups.google.com/group/nmeda-technician-corner>

Yet Another Successful Regional CAMS-HP!

By Pete Lucas



NMEDA's first 2012 Regional CAMS-HP was held May 18th at Bruno Independent Living Aids in metro Milwaukee with 31 attendees. This Training was co-sponsored by Mobility Works and Bruno. In addition to being great hosts, Bruno provided all attendees a fascinating tour of their production and finishing plant facilities. The attendees scored the course at 4.4 on 5.0 scale. The Regional CAMS-HP is designed for healthcare professionals (OT's, PT's, CDRS, VA, and Case Managers etc.) to have the opportunity to learn about the mobility equipment industry, partner with local mobility equipment dealers, and earn 7 contact hours of AOTA, ADED, AKTA and .6 CEU of RESNA Continuing Education credits.

Sally Sullivan, one of the eight "Train the Trainer" graduates from the 2010 ADED Conference in Kansas City, conducted the day long training. The attendees scored the course at 4.4 on 5.0 scale. Andrew Bayer from Bruno provided leadership and many volunteer hours to help make this event a success.

Our next Regional CAMS-HP course is scheduled for June 15 at Touro Rehab Center in New Orleans. There is also a new opportunity for Dealers to host 1.5 hour CAMS-HP Lunch & Learn sessions with local healthcare professionals.

For more information about this and other upcoming NMEDA Education & Training opportunities, please contact Pete Lucas at 800-833-0427 or pete@nmeda.org.

MOVING FORWARD WITH DRIVE MASTER



Experts Now!

Partial Features Include...

- Hand Controls
- Reduced Effort Steering
- Reduced Effort Braking
- Foot Steering
- Left Foot Gas Pedals
- Wheelchair Lifts
- Porch Lifts
- Steering Devices
- Backup Brakes & Steering
- Horizontal Steering
- Complete Van Conversions
- Block Pedal Extensions

And Much More! For additional information contact Drive-Master



Providing Mobility for the Physically Challenged Since 1952



37 Daniel Road West, Fairfield, NJ 07004
 Phone: (973) 808-9709 • Fax: (973) 808-9713
 E-mail: drivemaster@drivemaster.net
 Web: www.drivemaster.net

INNOVATION

More NMEDA Manufacturer Service Schools Coming Soon!

By Pete Lucas

This year we have 2 remaining Manufacturer Services Schools (MSS) scheduled. **They are:**

MSS - Buffalo: July 17-19, 2012
Hosted by Main Mobility, Clarence, NY

MSS - Phoenix: Oct. 8-10, 2012
Hosted by VMI, Phoenix, AZ



6-8 manufacturer certifications in one school.

“NMEDA offers trainings to conveniently keep your QAP required training certifications up to date...”

Benefits:

- Cost-effective intensive training, 6-8 manufacturer certifications in one school!
- Conveniently keep your QAP required training certifications up to date
- Learn best practice installation and diagnostic procedures from the experts
- Hands-on practice in every training session
- Opportunities to meet and learn from your peers



Hands-on practice in every training session.

Recent MSS Attendee feedback:

“I really enjoyed this training and it really did help in the areas I had trouble understanding.”

“Hands on really helped a lot.”

“I enjoyed seeing the differences between the different companies and applications offered.”

NMEDA Service School Manufacturer Presenter Registration

We send a Short Circuit to all NMEDA members announcing online registration for Manufacturer Presenters approximately 2-3 months in advance of each school. The limited slots are extremely competitive and in the past have sold out in less than an hour from announcement. Our objective is to be fair to everyone.

In order to be considered for an upcoming school as a presenter you must:

1. Be classified as a NMEDA Manufacturer in good standing
2. Submit a proposed written course syllabus and outline along with hands-on exercise explanation to Pete Lucas prior to registration
3. Understand that MSS slots are "first come, first served." If sold out, you will be placed on a standby list and notified if an opening becomes available.

Attendee Registration

Online registration for 2012 MSS and other details can be found in the training area of the NMEDA website. Space will be limited to 30 trainees, so make sure to take advantage of these valuable hands-on training opportunities before they sell out.

For more details, contact Pete Lucas at 800-833-0427 or email him at pete@nmeda.org

NMEDA Training Opportunities

For Technicians

Electrical Training - Part One Online Anytime!
Basic Electrical Concepts.

Electrical Training - Part Two Onsite
Hands-on Electrical Training. (Locations TBA)

Manufacturer Service Schools Onsite
Classroom and Hands-on Product Training. April 2012 (Tampa)
July 2012, Oct 2012

For Members and All Staff

Dealer Sales Training Online Anytime!
Primer on Mobility Industry players, products, medical awareness and sales best practices.

QAP 1 - Introduction Online Anytime!
Explains many benefits Dealers will realize (No Cost!)
from QAP and gives details on the quick 6-step enrollment process.

QAP 2 - Audit Preparation Online Anytime!
Step by step guide through the QC Manual, (No Cost!)
pre-inspection preparation, and post-inspection accreditation.

QAP 3 - Guidelines Training Online Anytime!
"How-to" guide on understanding and implementing (No Cost!)
NMEDA Guidelines best practices. Certificate upon completion by request.

For Healthcare Professionals

CAMS-HP Regional Onsite
For .7 CEU credit course designed for CDRS, (Regional
OT, and other professionals on key issues in Locations TBA)
the mobility equipment industry taught by certified trainers.

CAMS-HP Lunch & Learn Onsite
For 1 CEU course designed for CDRS, OTs and (View Schedule at
other professionals on key issues in the mobility www.nmeda-camshp.org)
equipment industry taught by certified dealers. (At your dealership or local rehab center.)



On the Web...

To view more information pertaining to NMEDA Training Opportunities visit the NMEDA website at <http://members.nmeda.org/members/training/>.

Solutions that Sell!

Now available in Toyota, Honda
and VW Routan



Toyota Sienna

Rear entry Vision minivan conversions accommodate virtually all types of scooters and wheelchairs and provide safer and more convenient travel for persons with disabilities, whether traveling alone or assisted. Choose from an impressive range of options to meet your customer's requirements and budget.

Vision conversions are offered in other popular models of new and used production minivans, including Chrysler, Dodge, Ford and General Motors.

The *Vision*[™]
by Viewpoint Mobility

North America's premier wheelchair access minivan



Call 1-877-368-6022
or visit www.viewpointmobility.com

New, Simpler, More Logical Label Reporting Form

*Many Dealers Have Been Asking For It...
Now Here It Is!*

The first annual Product Sales Summary report will be released soon from the data RADCO has been compiling from our reports since July 1, 2011. With this information, we should begin to get an idea about our sales mix as an industry.

This will be helpful when we lobby funding sources, insurance companies, NHTSA, VA, Voc Rehabs, etc. For the first time, we will have industry wide data about our sales mix and our impact into the marketplace.

All NMEDA members will be able to see the annual compilation of this data. You can see how your sales mix compares to the industry as a whole.

This new report form should be easier to navigate and will eliminate most of the guesswork when completing the form. The sales by category are generic; they are not brand specific. Manufacturers will be able to see total sales for a category and then can make improvements or adjust pricing to gain better market share. That will be good for everyone.

- All sensitive customer information has been removed, so that no dealer's customer list could ever be compromised.
- Only RADCO will have this information, and no dealer specific information will be shared with anyone at NMEDA.
- The new form will make next year's data (July 2012 through June 2013) even more accurate and clear-cut!

**Please begin using this form immediately.
(By July 1 at the latest.)**

A copy of this report for all monthly QAP jobs is to be mailed, or scanned/emailed to RADCO along with the QAP label log for that month by the 10th of the following month. **You may find the new form located to the right.**

Thanks for your help in implementing the new form.

--- The QAP Committee

NMEDA LABEL REPORTING FORM

NMEDA/QAP Label # N- _____

DEALER NAME: _____ DEALER CITY & STATE: _____

VEHICLE YEAR/MAKE/MODEL: _____ DATE COMPLETED: _____

MOBILITY VEHICLE TYPE: CONSUMER MINIVAN PICKUP LOWERED FLOOR RAISED DOOR
 COMMERCIAL FULL SIZE VAN OTHER RAISED ROOF

IF CONVERSION, MANUFACTURED BY: _____

IS THIS A PASS-THROUGH OF THE CONVERSION WITH NO ADDITIONAL WORK PERFORMED? YES / NO

HAS AN OUTSIDE DEALER PERFORMED WORK ON THIS VEHICLE? YES / NO IF YES, PLEASE PROVIDE THE FOLLOWING INFORMATION:

DEALER NAME: _____ DEALER PHONE NUMBER: _____

DEALER CITY & STATE: _____ DEALER **QAP LABEL** NUMBER: _____

PLEASE CHECK ALL WORK PERFORMED BY THE OUTSIDE QAP DEALER:

Reduced Effort Steering _____ Reduced Effort Braking _____ Horizontal Steering _____ Raised Roof _____ Raised Door _____ Lowered Floor _____

Other Equipment – List _____

Please darken the box to indicate equipment installed. Please show if the equipment is new or used by circling selection. CHECK ALL THAT APPLY TO THE VEHICLE. *Serial numbers are optional.*

UNOCCUPIED LIFTS *New/Used*
S/N _____

- IN-VEHICLE ROTARY HOIST
- IN-VEHICLE PLATFORM LIFT
- PICK-UP BED MOUNT HOIST
- TRUNK MOUNT HOIST
- HITCH MOUNT LIFT
- HITCH MOUNT + WHEELS
- HITCH MT MANUAL CARRIER
- TRAILER
- ROOF TOP CARRIER
- OTHER _____

ADAPTIVE SEATING *New/Used*
S/N _____

- INTERIOR TRANSFER BASE
 - 4-Way 6-Way 8-Way
- INSIDE to OUT TRSFR SEAT
- ELEVATING SEAT PLATFORM
 - Interior mounted
 - Exterior mounted
- TRANSFER SLING LIFT
- OTHER _____

HAND CONTROLS *New/Used*
S/N _____

- PUSH / PULL
- PUSH / TWIST
- PUSH / RIGHT ANGLE PULL
- PUSH / ROCK
- FLOOR MOUNT
- STEERING RING ACCELL.
- BRAKE ONLY HAND CTRL
- GAS / BRAKE SERVO
- JOYSTICK
- OTHER _____
- Safety Device Added**
- PEDAL GUARD

STEERING DEVICES *New/Used*

- SPINNER CUFF
- AMPUTEE RINGS
- SPINNER KNOBS
- TRI - PIN SPINNER KNOB
- U - GRIP
- V - GRIP
- PALM GRIP
- OTHER _____

OTHER DRIVING AIDS *New/Used*
S/N _____

- LEFT FOOT ACCELERATOR
- PARKING BRAKE EXTENDER
- CROSS OVER GEAR SHIFTER
- GEAR SHIFTER EXTENSION
- PEDAL EXTENSIONS
- DASH LEVER EXTENSIONS
- ADAPTED KEY HOLDER
- OTHER _____

SECONDARY CONTROLS, ELEC
S/N _____

- ELECTRIC PARKING BRAKE
- HORN / TURN SIGNALS
- ELECTRONIC GEAR SHIFT
- HVAC CONTROLS
- OTHER _____
- RAIN ACTIVATED WIPERS
- BACKUP SENSOR/CAMERA
- Activation Method**
- TOGGLE SWITCH
- TOUCH PADS
- HEADREST SWITCH
- ELBOW SWITCH
- VOICE ACTIVATED
- OTHER _____

STEERING MODIFICATIONS
S/N _____

- COLUMN EXTENSION- _____ " (6" Max)
- WHEEL EXTENDER RING- _____ "
- DEEP DISH STEERING
- HORIZONTAL STEERING
- FOOT STEERING
- STEERING WHEEL Dia. _____ "
- ZERO EFFORT
- REDUCED EFFORT
- BACK-UP SYSTEM
- OTHER _____

BRAKING MODIFICATIONS
S/N _____

- REDUCED EFFORT
- ZERO EFFORT
- BACK-UP SYSTEM

OCCUPIED LIFTS *New/Used*
S/N _____

- SINGLE POST PLATFORM LIFT
- DUAL POST PLATFORM LIFT
- UNDER VEHICLE LIFT
- BETWEEN THE FLOOR LIFT
- Lift Safety Device Added**
- TRANSMISSION INTERLOCK

DOOR OPENERS *New/Used*
S/N _____

- POWER DOOR SLIDE
- POWER DOOR SWING - SIDE
- POWER DOOR SWING - REAR

LIFT & POWER DOOR SWITCHES

- MAGNETIC SWITCHES
- TOGGLE / KEY SWITCHES
- DASH SWITCHES
- WIRELESS REMOTE
- HANDHELD PENDANT

WHEELCHAIR SECUREMENT (TIE-DOWNS) *New/Used*
S/N _____

- MANUAL 4-PT BELTS
- RETRACTABLE BELTS
- ELECTRIC W/C LOCKDOWN
- DRIVER W/C STABILIZER

OCCUPANT RESTRAINTS

- LAP BELT(S)
- SHOULDER BELT(S)
- PASSIVE DRIVE-IN BELTS
- TORSO STRAP
- OTHER _____

RAISED ROOFS/DOORS

- STRUCTURAL METAL CAGE
- RAISED FIBERGLASS TOP
- EXTENDED DOOR
- EYEBROW KIT

LOWERED FLOORS

- CARGO LOWERED (CENTER)
- DRIVERS LOWERED FLOOR
- FULL DROP FLOOR
- LOWERED FLOOR _____ inches
- LOWERED FLOOR-TRUCK
- PWR ELEVATING PLATFORM _____ inches
- GAS TANK MODIFICATION
- WHEEL WELLS
- OTHER _____

INTERIOR FINISHES

- WINDOWS
- WALLS
- FLOORING
 - STEEL PLYWOOD
- HEADLINER
- OTHER _____

OTHER AUTOMOTIVE SEATING *New/Used*

- FORWARD FACING
- SIDE FACING
- SOFA BED
- 1 PASSENGER SEAT
- 2 PASSENGER SEAT
- 3 PASSENGER SEAT
- OTHER _____

MISC. EQUIPMENT *New/Used*

- DUAL BATTERY SYSTEM
- DRIVER TRAINING BRAKE
- PORTABLE / MANUAL RAMPS
- CAMPER SHELL LFTER
- WHEELCHAIR BACKREST / HEADREST
- TRANSFER HANDLES/BARS
- REMOVABLE DRIVER SEAT BASE
- OTHER _____

Proposed Changes to FMVSS 210 Test Method

By Jacques Bolduc, P. Eng.

NHTSA has published a notice of proposed rule-making (Docket No. NHTSA-2012-0036) that would change the test devices (body blocks) used to demonstrate compliance to the static pull test requirements of the seat belt assembly anchorage standard (FMVSS 210). The new test devices come in two sizes. The smaller one would be used only if the larger one does not fit properly in a designated seating position. Use of the smaller one is allowed only if, after following a specific positioning method, there is contact between test devices when installed in adjacent seating positions.

The NPRM also introduces a requirement for the seat belt to be “snug” against the test device. “Snug” refers to when enough slack is removed from the seat belt such that a 1 1/4 inch diameter wooden rod will not pass between the FAD and the belt when a maximum force of 2.22 N (1/2 lb-force) is applied tangent to the DAD shoulder or lap belt interface.

NHTSA proposes that compliance with the new test devices be required three years from the date of publication of the final rule. The agency would use the FADs to test vehicles manufactured on or after the first September 1st that is three years from the date of publication of the final rule. Optional early compliance would be permitted.

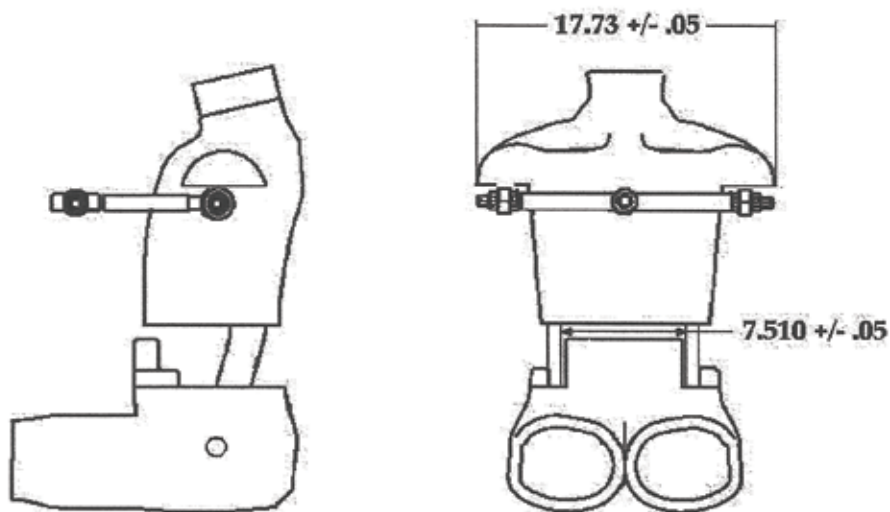

Force Application Device 1 (for illustration purposes)

“NHTSA has published a notice of proposed rulemaking that would change the test devices used to demonstrate compliance to the static pull test requirements of the seat belt assembly anchorage standard...”

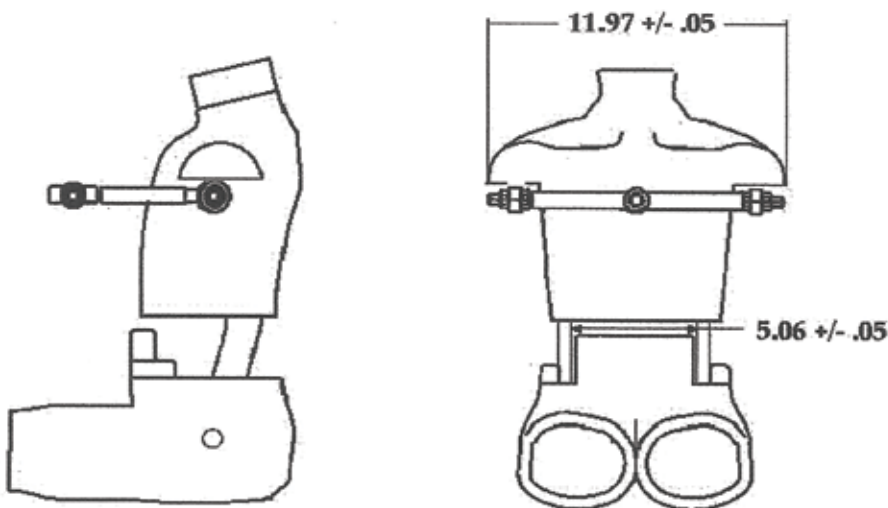

Force Application Device 2 (for illustration purposes)

Brake-Throttle Override: Proposed Changes to Accelerator Control Systems - FMVSS 124

By Jacques Bolduc, P. Eng.

Attention hand control manufacturers:

The accelerator control standard is being upgraded (Docket No. NHTSA-2012-0038) to address the return to idle of electronic throttle controls and to introduce a brake-throttle override (BTO) requirement. The return to idle upgrade considers the many failure modes of electronic throttle systems.

The proposed BTO requirements are intended to eliminate conflicting throttle and brake inputs by overriding the throttle input. The proposed standard requires a vehicle be

equipped with an override system and specifies stopping distances when the BTO is activated. The NPRM states "On a vehicle equipped with a BTO system, if for any reason an accelerator pedal fails to return after the driver stops pressing on it, BTO will engage as soon as the driver applies the brake pedal (there may be a delay

that drivers are accustomed to, even though it may be clear that something out of the ordinary has occurred."

Compliance with the upgraded FMVSS 124 would be required within two years from the next September 1 of the date of publication of the final rule.

“ The accelerator control standard is being upgraded to address the return to idle of electronic throttle controls and to introduce a brake-throttle override (BTO) requirement...”

built into the system on the order of one second; in some systems, other pre-conditions have to be met for the BTO to engage, as discussed below). By intervening in this way, the BTO system essentially gives the brake pedal priority over the accelerator pedal, allowing for normal braking. Thus, the vehicle can be brought to a stop with an amount of pedal effort

B&D
INDEPENDENCE, INC.

Safe Independent Mobility
*Safety and Comfort
never looked or
felt this good!*

www.bdindependence.com

FMVSS
GOVERNMENT OF CANADA

NMEDA Thanks and recognizes these manufacturers for their participation in this voluntary discount program that enhances the benefits of the Quality Assurance Program (QAP).

Adaptive Driving Alliance

(Requires Membership)

4218 W. Electra Lane
Glendale, AZ 85310
623-434-0722 phone
www.adamobility.com

Pride Mobility Products Corp.

182 Susquehanna Avenue
Exeter, PA 18643
570-655-5574 phone
www.pridemobility.com

Vantage Mobility International (VMI)

5202 South 28th Place
Phoenix, AZ 85040
800-348-8267 phone
www.vantagemobility.com

Freedom Mobility

2075 47th St.
Sarasota, FL 34234
800-833-0478 phone
www.freedomlifts.com

Q'Straint

5553 Ravenswood Road #104
Ft. Lauderdale, FL 33312
800-987-9987 phone
www.qstraint.com

Worldwide Mobility Products

720 N. Golden Key St, Suite B6
Gilbert, AZ 85233
480-497-4692 phone
www.worldwide-mobility.com

*** NMEDA is unable to provide information with regard to the individual company discounts. Dealers who are participating in the NMEDA Quality Assurance Program should contact their sales representatives from the above companies for additional details about their discount program.

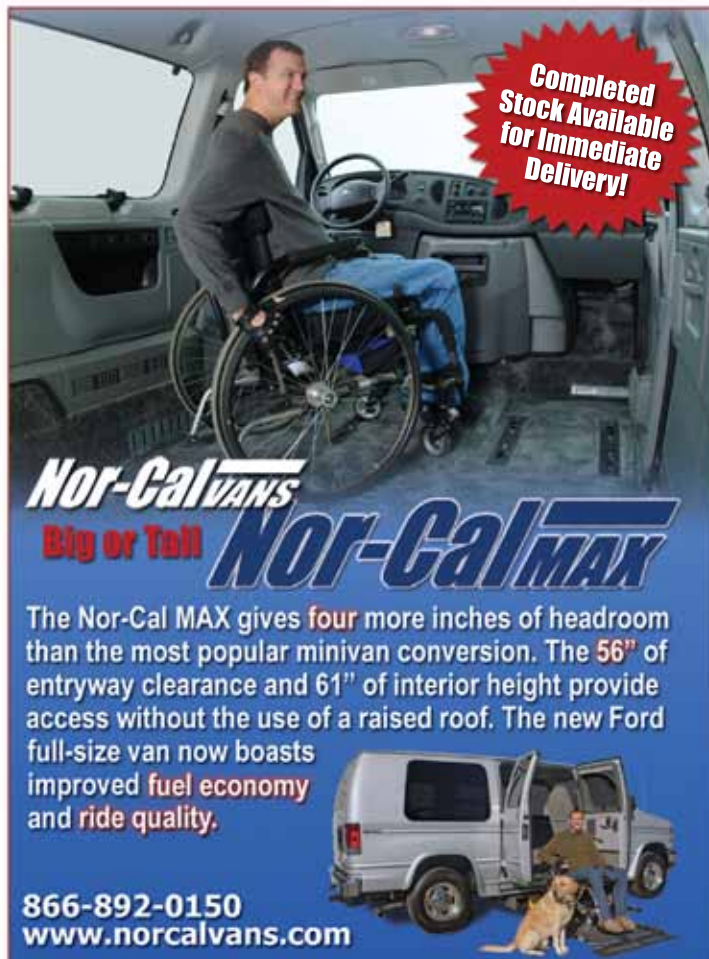

Completed Stock Available for Immediate Delivery!

Nor-Cal Vans
Big or Tall **Nor-Cal MAX**

The Nor-Cal MAX gives **four** more inches of headroom than the most popular minivan conversion. The **56"** of entryway clearance and **61"** of interior height provide access without the use of a raised roof. The new Ford full-size van now boasts improved **fuel economy** and **ride quality**.

866-892-0150
www.norcalvans.com



Wheelchair Getaways
over a decade of quality service

Accessible Van Rentals

Wheelchair Getaways is the leader in accessible van rentals, serving over 450 cities nationwide. By providing quality service, Wheelchair Getaways has delivered freedom and independence to people with disabilities for over fifteen years..

Call today and let us serve you!

National Reservations
1-800-642-2042
www.wheelchairgetaways.com

- Short or Long Term
- Medical Visits
- Quality Service
- Occupational Therapy
- Vacations
- Insurance Replacement
- Spacious Interiors
- Shopping
- Vocational Rehabilitation
- Ramps or Lifts
- Try Before You Buy
- Hospital Visits
- Pick-up and Delivery
- Interim Vehicles

YOUR AD HERE!

Imagine
the Possibilities.

ACCESS ATOP
BY CLOCK CONVERSIONS

Automatically lift and lower your truck top
with Clock Conversions' *AccessATop!*



BECOME A DEALER TODAY!

Clock Conversions

6700 Clay Ave SW

www.clockconversions.com

Grand Rapids, MI 49548

800-732-5625 ext. 304



Crescent Industries

191 Washington St. Auburn, ME 04210
207 777-3500 fax 207 777-3522

State of the Art Adaptive Vehicle Control Products



VoiceScan - Activate a switch and a voice announces your functions such as wipers, horn, lights, etc. When you hear the

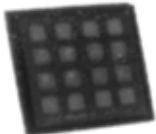

Command 16 - A 16 switch lighted Electronic Console to control the secondary functions of your vehicle such as lights, ignition, windows, heater



Remote Controls - Remote controls for all wheelchair lifts including Ricon, Crow River, Braun, Mobile - Tech, I. M.S. and others. They can be purchased with magnetic entry and dash controls.

Visit our web site at www.crescentindustries.com

State of the art Adaptive Vehicle Control Products

Crescent Industries has been manufacturing reliable vehicle control products for many years from complete systems to an individual relay pack to help with the small jobs.

At Crescent, we do not lose sight of our mission *to help others.*

We believe in handing a person the key to unlock the door of dependency and to enter the world of independence. We have Can Do attitude!

New product!

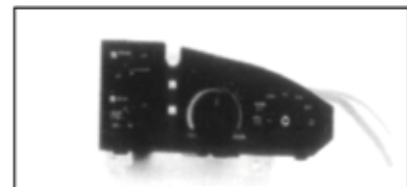



CANADIAN PRESIDENT'S REPORT

DAVID HUTCHISON

(SPARROW HAWK INDUSTRIES, LTD. - WATERLOO, ONTARIO)

One of the founding owners of Sparrow Hawk Industries, David has been in the vehicle mobility industry for 16 years. He started assisting NMEDA Canada during his first year in the industry on the Finance committee, and has been on many committees surrounding finance, compliance, testing and Canadian Conferences over the years. Concerns or questions may be directed to him at canada@nmeda.org.

Here it is Victoria Day, and after spending the day with the family, here I write!

The Mobility Awareness Month has been a huge success! Thank you to all that have worked hard to bring this month to fruition! With the number of people that have visited the NMEDA site, it is amazing how much awareness has been generated, and so thank you all that supported this endeavour, which brought this awareness to those outside of our industry boundaries.

easier. As that rolls off my fingers, we have moved the translating task back to our original translator from a few years ago, and she is translating the 2012 guidelines. We will be translating all of the documents that we have, and will be closely monitoring all document changes so that we will be able to keep the French version of the documents current.

As you are aware, the Transport Canada committee wrote to transport Canada to request a system in which slightly used vehicles could be moved across the border for lowered floor modification. In February we received a letter back that raised some concerns that Transport Canada had about the work that we had done, so we tried to address

As always, if you have any questions or concerns, please do not hesitate to contact me or any other board member to have your questions addressed!

David Hutchison

As always, please contact me if I can help with anything!

“ The Mobility Awareness Month has been a huge success! Thank you to all that have worked hard to bring this month to fruition!”

At the meeting that we had in Phoenix, we discussed the fact that the board would be involved with the committees in the US to continue to try to Canadianize American documentation so that information is more international. Having to maintain only one set of forms and documents will make administration much

those concerns in a letter we sent in March. We have not heard back yet from Transport Canada.

I know that there are some changes coming to seating and seat position requirements in September, and will follow up with more information in the fall article.

David Hutchison, President

Sparrow Hawk Industries, Ltd.
675 Davenport Road
Waterloo, ON N2V 2E2
519-884-4295 phone
519-884-1924 fax
davidh@sparrowhawk.ca

Ed Stang, Vice President

Can Am Mobility
258 Old Vernon Road
Kelowna, BC L6T 4K3
250-491-0003 phone
250-491-1044 fax
ed@canammobility.com

Melody Chamberlain, Secretary

PG Surg-Med, Ltd.
1749 Lyon Street
Prince George, BC V2N 1T3
250-564-2240 phone
250-564-2243 fax
melody.chamberlain@pgsurgmed.com

Bob Nunn, Treasurer

Creative Carriage Ltd.
6 Ridgeview Street
St. George, ON N0E 1N0
800-392-8403 phone
bob@creativecarriage.com

Jacques Bolduc, Associate Member

SRD Bolduc, Inc.
265 rue St-Louis
St-Therese, QC J7E 5E3
813-410-4884 phone
srd@videotron.ca

Gina Lewis, Manufacturer Rep.

Adapt-Solutions
145 Damase-Breton
St-Lambert, QC G0S 2W0
866-641-0419 phone
ginalewis@adapt-solutions.ca



mga
mga research corporation

**MGA Research –
Your FMVSS 207/210/222 &
SAE J2249: Seating System,
Seat Belt Anchorage and Wheelchair
Anchorage Testing Experts!**

email: jessica.gall@mgaresearch.com
phone: (262) 763-2705
web: www.mgaresearch.com

The advertisement features three photographs: the top one shows a complex mechanical testing rig; the middle one shows a person in a wheelchair on a test platform; the bottom one shows a vehicle interior with a wheelchair mounted in the back seat.



REGIONAL REPORTS

Who Represents You?

These representatives are your voice. If you have any concerns or issues that you need clarification on, call or email your Regional or Associate representative and they will assist you in any way they can. The representatives also write a quarterly article about things that are happening in your region. If you have any information that you would like to share with them, please feel free to contact them.

Southern Region

Richard May

United Access
2165 Hillshire Circle
Memphis, TN 38133
901-888-1010 phone
901-888-1009 fax
richard@unitedaccess.com

States Include:

Alabama, Florida, Georgia, Kentucky, Mississippi, North Carolina, South Carolina, Tennessee, Virginia and West Virginia

Midwest Region

Bob Lundin

IMED Mobility
200 East 1st St.
Tea, SD 57064
605-498-1601 phone
605-498-2202 fax
bob@imedmobility.com

States Include:

Arkansas, Illinois, Iowa, Kansas, Louisiana, Minnesota, Missouri, Nebraska, North Dakota, Oklahoma, South Dakota, Texas and Wisconsin.

Northern Region

Ron Mohr

Clock Mobility
6700 Clay Ave.
Grand Rapids, MI 49548
800-732-5625 phone
616-698-9495 fax
ronm@clockconversions.com

States Include:

Connecticut, Delaware, Indiana, Maine, Maryland, Massachusetts, Michigan, New Hampshire, New Jersey, New York, Ohio, Pennsylvania, Rhode Island and Vermont.

Western Region

Dan Drury

New Horizon Vans, Inc.
3825 Osuna N.E., Suite 1
Albuquerque, NM 87109
505-884-2492 phone
505-884-8007 fax
dan@newhorizonvans.com

States Include:

Alaska, Arizona, California, Colorado, Hawaii, Idaho, Montana, Nevada, New Mexico, Oregon, Utah, Washington and Wyoming.

Canada Representative

David Hutchison, Canadian President

Sparrow Hawk Industries, Ltd.
675 Davenport Rd.
Waterloo, ON N2V 2E2
519-884-4295 phone
519-884-1924 fax
davidh@sparrowhawk.ca

Associate Representative

John Anschutz, Associate Rep.

Shepherd Center
2020 Peachtree Rd. NW
Atlanta, GA 30309
404-350-7720 phone
404-350-7356 fax
john_anschutz@shepherd.org

SOUTHERN REGIONAL REPORT

By Richard May

When we don't promote our business and NMEDA, QAP clients suffer! There is no doubt we as NMEDA Dealers recognize that our business needs clients and profits. That is basic business. But what we may not always recognize is just how terrible of a disservice we are doing to the disabled clients we serve if we do not aggressively get our message out to them about our products, services and what makes us special.

To make this point I will share a recent experience. A prospective client called our store interested in a turning automotive seat. We were glad to oblige and arranged a demonstration at their home for their convenience. When we arrived we learned that they had recently purchased a scooter lift for their brand new minivan from a business that is not a member of NMEDA. I took a look at the lift. I asked the user, "why the pillows under the platform and near the mast?" His response: "You know, for \$3,000 we didn't expect this. It rattles something horrible and the guy where we bought it told us that we were just going to have to deal with it!" Knowing a thing or two about this lift, we got rid of the rattle in about 10 minutes!

After demonstrating the turning seat we realized the client really did not need it yet. He got in and out pretty well for now. We told him, "Since you have already used your \$1,000 Mobility Rebate on the lift, there is no real urgency to get the seat until you really need it. We will be here for you when you do." His response: "What is a \$1,000 Mobility Rebate?" That's right, the business that sold him the lift knew so little about the industry they did not let the client know about the Chrysler Mobility Rebate!

We left that call dejected. Upset we didn't make a sale? Sure. But we were MORE upset that we let that family down. By not doing OUR job of letting him know who we are, what we do and why, as a NMEDA QAP Dealer we are better we allowed him to make a bad decision. Shame on us!

Promoting our business and promoting NMEDA QAP has more to do than just growing our business and providing us all with jobs and income. It has just as much to do with us not letting a person who really needs a correct, dependable and quality adaptive automotive solution make a purchase they will regret.

This article was sent in by a dealer. He wished to remain anonymous. I can add that we have experienced this type of situation here at UA. We are arrogant enough to believe when we allow a customer to buy from someone else we have done them a disservice. We call it customer service before the sale. We believe we have always had great customer service after the sale. However we haven't always been great before the sale. About 3-4 years ago we made this a huge focus for our sales team. We have improved greatly, however we still have a long way to go. I want to thank the author for taking the time to write something that we believe is pertinent to all dealers.

NORTHERN REGIONAL REPORT

By Ron Mohr

With spring behind us and the summer selling season here, I trust that this issue of the Circuit Breaker finds you well. Many things happened this spring including the NMEDA Mobility Awareness Month program, the NJ Abilities Expo, the Chrysler Group Mobility Awareness event and MPD/Veigel North Americans Grand Opening celebration to mention a few.

The Mobility Awareness Month program was a huge success for NMEDA, the dealer members and especially the winners of the three vehicles that were awarded. Although there were some challenges early on in the program, we left the contest better educated by the experience and the feedback we have received has been very positive.

The Addison Abilities Expo was a great event, as usual, and there were many dealer and manufacturer NMEDA members represented. Bussani Mobility took to opportunity to present a workshop on the NMEDA CAMS-HP. I would encourage you to explore the CAMS-HP program at your dealership if you haven't already as it is a great tool to get you connected with the people that recommend the equipment, products and services that you provide.

MPD/Veigel NA held a grand opening in May at their Shelby Township, Michigan facility that was well attended by several mobility dealers, driver evaluators, manufacturers, and local officials. The Veigel event coincided with an event held at Chrysler headquarters earlier in the week which was designed to raise awareness of Chrysler employees of how the products they manufacture are used in the mobility industry. NMEDA also had representation at the Chrysler event with Dave Hubbard and Bill Fredo in attendance.

As always, there is a lot going on in the industry and especially in the North Region of NMEDA. Dealers in this region seem to make things happen and get things done! If have anything you would like to bring to the NMEDA board, any of the committees or share with the rest of the membership, please feel free to contact me.

MIDWEST REGIONAL REPORT

By Bob Lundin

No report this month.

WESTERN REGIONAL REPORT

By Dan Drury

It appears National Mobility Awareness Month is one of the most popular ideas to ever come out of NMEDA. The meat and potatoes of this organization are initiatives like QAP, Guidelines, Education and Training and Manufacture Compliance. To our customers...blah blah, blah blah. But when we offer our customers an opportunity to win a free van we have given them something tangible enough to raise the interest level.

The success of this campaign was not all positive news. The first weekend after NMAM began we promoted it at the Albuquerque MS Walk. Monday morning our first calls were from concerned people who could not get on the website or could not vote. Who knew this little promotion would overwhelm multiple servers, especially the first week of the first year? In the end we had dozens of engaged people, a number who didn't know our company before, who know much more about us now. As the promotion was winding down we had many people ask us if it would happen again. I can't wait to see the response next year.

As all the fun was going on, your NMEDA committees were hard at work on the previously mentioned meat and potatoes. The QAP committee, and especially Bill Fredo, is working with RADCO to improve the inspection process. Our main goal is greater consistency shop to shop and region to region. Your timely feedback after inspection is a key to reaching this goal. Please complete the form you receive after your QAP inspection ASAP and send it in.

The Conference committee is investigating several ways to improve the value of the annual conference for all members. It is looking into adding presentations that will help with business and sales improvement for our stores. The committee also wants to improve all the presentations by reviewing outlines of each presentation prior to the conference.

The Education and Training committee always seems to be a hub of activity. They are constantly working on ways to improve and expand hands-on and online training opportunities for members.

In VA/Government Relations the late payments problem is always being addressed. They have also arranged to have an exhibit at the PVA games beginning June 24th.

To see what the other committees are working on, go to the NMEDA website and look for the board of directors consent agendas. If you have any questions or comments, please call me. And if you get a chance call the NMEDA office and thank them for all the work they do. We wouldn't get much done without them.

Have a great and profitable summer!

MANUFACTURE YOUR OWN PERSONALIZED AND COMPLIANT REAR ENTRY CONVERSION

- ▶ Fully Compliant to FMVSS/CMVSS and ADA Standards!
- ▶ Full manufacturing instructions, drawings and in-house training provided!
- ▶ Seats up to seven passengers or up to six passengers and one wheelchair

**Reduce your delivery delays!
Increase your profits!**

For more information contact
Graham Edney at 604-792-2082 or e-mail
graham@sidewinder-conversions.com

**Opportunities
still available
across the
United States
and Canada!**

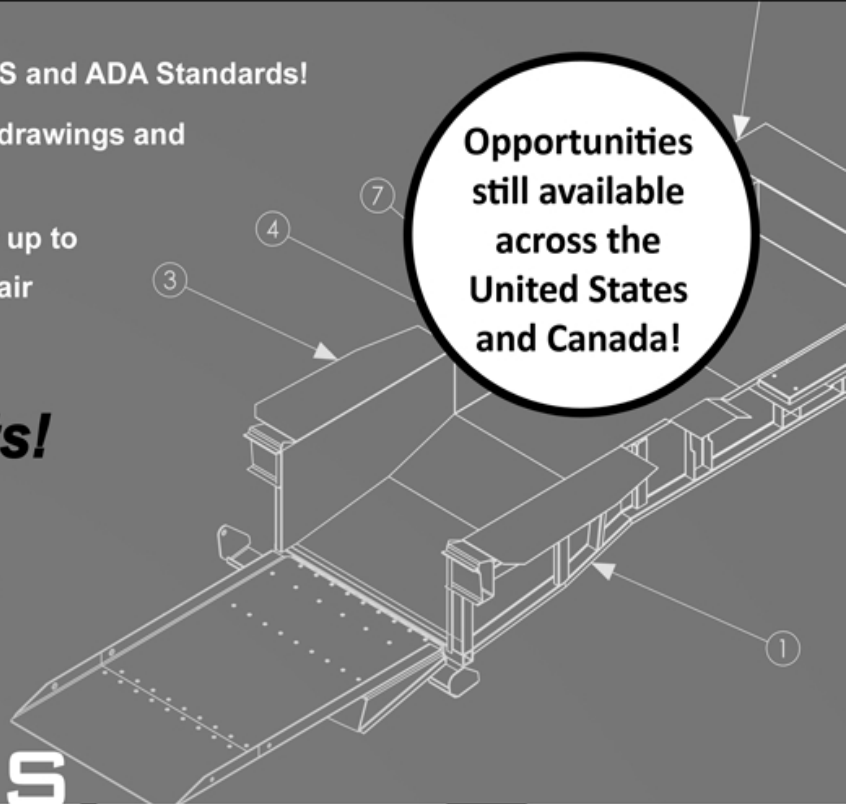

TURN THIS INTO THIS

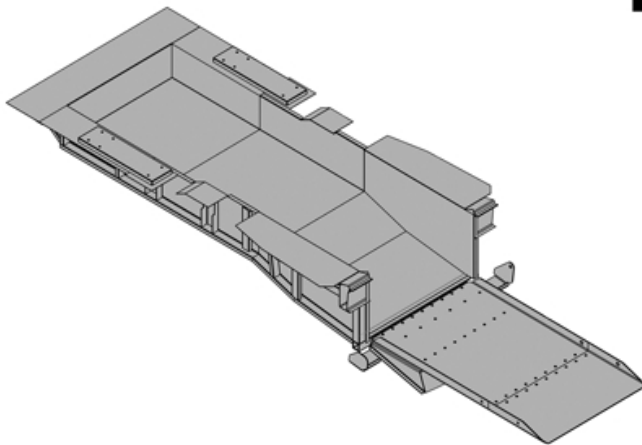

2005 - 2012 DODGE GRAND CARAVAN REAR ENTRY CONVERSION



SIDEWINDER CONVERSIONS & MOBILITY
604.792.2082 TOLL FREE: 888.266.2299

ARIZONA

Vantage Mobility International
5202 S. 28th Place.
Phoenix, AZ 85040
800-348-8267

CALIFORNIA

Ability Access LLC
31121 Mission Blvd. #165
Hayward, CA 94544
209-239-3800

Driving Systems, Inc.
16139 Runnymede St.
Van Nuys, CA 91406
818-782-6793

KEMPF
1245 Lakeside Dr. #3005
Sunnyvale, CA 94085
408-773-0219

Manufacturing Production Services Corp.
2222 W. Enterprise St.
Escondido, CA 92029
800-243-4051

Toyota Motor Sales, USA, Inc.
19001 S. Western Ave. H205
Torrance, CA 90509-2714
310-468-0469

Transfer Flow, Inc.
1444 Fortress St.
Chico, CA 95973
530-893-5209

COLORADO

Medved Autoplex - MV1 of Colorado
11001 W. I-70 Frontage Road N.
Wheat Ridge, CO 80033
303-421-0100

FLORIDA

Freedom Mobility, LLC
2075 47th St.
Sarasota, FL 34234
800-833-0478

MCMC LLC
4625 E. Bay Drive #222
Clearwater, FL 33764
727-535-0905

Merits Health Products
730 NE 19th Place
Cape Coral, FL 33909
239-772-0579

Q'Straint / Sure-Lok
5553 Ravenswood Rd., #110
Ft. Lauderdale, FL 33312
954-986-6665

Seatbelt Solutions
15835 Corporate Road North
Jupiter, FL 33478
561-747-7165

GEORGIA

Adaptive Mobility Systems, Inc.
5555 Oakbrook Pkwy Suite 555
Norcross, GA 30093
770-662-5242

HAWAII

Soderholm Sales & Leasing, Inc.
2044 Drillingham Blvd.
Honolulu, HI 96819
808-834-1417

ILLINOIS

B & D Independence
1024 Empire Street
Mt.Carmel, IL 62863
618-262-7117

Freedman Seating
4545 W. Augusta Blvd.
Chicago, IL 60651
773-524-2440

Wells-Engberg Co., Inc.
129 S. Phelps Ave., #920
Rockford, IL 61108
800-642-3628

INDIANA

Ace Mobility LLC
9850 East 30th Street
Indianapolis, IN 46229
317-241-2444

AOI Electrical
7988 Centerpoint Drive, Ste 400
Indianapolis, IN 46256
800-480-6680

Braun Corporation
P.O. Box 310
Winamac, IN 46996
800-843-5438

Prime-Time Specialty Vehicles, Inc.
56616 Elk Park Dr.
Elkhart, IN 46516
574-293-9191

KANSAS

El Dorado National
1655 Wall St.
Salina, KS 67402
785-827-1033

LOUISIANA

E.Z. Lock
2001 Wooddale Blvd.
Baton Rouge, LA 70806
225-214-4620

MAINE

Crescent Industries
191 Washington St.
Auburn, ME 04210
207-777-3500

Electronic Mobility Controls, LLC
26 Gabriel Dr.
Augusta, ME 04330
207-512-8009

MICHIGAN

Auto Ability
8105 Big Lake Road
Clarkston, MI 48347
248-620-4200

Chrysler Special Vehicle Sales
800 Chrysler Dr.
Southfield, MI 48326
800-255-9877

General Motors Corporation
100 Renaissance Ctr.
MC482-A20-B98
Detroit, MI 48265
313-667-8682

Mobility Transportation Services, Inc.
42000 Koppernick, #A3
Canton, MI 48187
734-453-6452

Nissan North America, Inc.
39001 Sunrise Drive
Farmington Hills, MI 48331
248-488-4812

The Vehicle Production Group
333 Republic Drive
Allen Park, MI 48101
248-248-1650

Veigel North America
51277 Celeste Drive
Shelby Twp, MI 48315
586-790-2970

View Point Mobility
1815 Palmer Street
Kalamazoo, MI 49001
877-368-6022

NORTH CAROLINA

Autochair USA
1168 North Main Street
Lillington, NC 27546
910-814-1350

NEW YORK

Karsan USA LLC
885 Second Avenue
New York, NY 10017
917-337-6389

PENNSYLVANIA

Pride Mobility Products Corp.
182 Susquehanna Avenue
Exeter, PA 18643
570-655-5574

TEXAS

Independent Driving Systems
580 T.C. Jester Blvd.
Houston, TX 77007
713-864-1460

VIRGINIA

Dirivng Aids Development Corp.
9417 Delancy Drive
Vienna, VA 22182
703-938-6435

WISCONSIN

Bruno Independent Living Aids
1780 Executive Drive
Oconomowoc, WI 53066
262-953-5396

CANADA

BRITISH COLUMBIA

Mahadev Metal Works & Fabrication
Unit 124, 125 - 11071 Bridgeport Rd.
Richmond, BC V6X 1T3
604-270-3317

Sidewinder Conversions & Mobility
44658 Yale Road West
Chilliwack, BC V2R 0G5
604-792-8920

MANITOBA

Atom-Jet Industries
2110 Park Avenue
Brandon, MB R7B 0R9
800-573-5048

Van Extras
465 Lucas Avenue
Winnipeg, MB R3C 2E6
204-783-8267

NEW BRUNSWICK

Howell Ventures Ltd.
4850 Rt. 2 Hwy
Upper Kingsclear, NB E3E 1P8
506-363-5289

ONTARIO

Conna Corp.
6 Ridgeview St., P.O. Box 600
St George, ON NOE 1N0
800-591-7185

Savaria Vehicle Group
107 Alfred Kuehne Blvd
Brampton, ON L6T 4K3
800-561-9600

QUEBEC

Adapt-Solutions
145 Damase-Breton
St-Lambert, QC G0S 2W0
866-641-0419

SASKATCHEWAN

Automobility Manufacturing Corp.
1444 Lorne Street
Regina, SK S4R 2K4
306-791-9840

Golden Mobility & Rehab LTD
2202 Hanselman Ave.
Saskatoon, SK S7L 6A4
306-242-9060

INTERNATIONAL

UNITED KINGDOM

Alfred Bekker Ltd.
Kellythorpe, Driffield
East Yorkshire, England YO25 9DJ
44(0) 1377-241700

ITALY

Guidosimplex SNC
Via Podere S. Giusto, 29-00166
Roma, Italy
066-152-8005

ALASKA

TrailerCraft, Inc.

Melissa Gould
1301 East 64th Ave.
Anchorage, AK 99518
907-563-3631

ALABAMA

LynLo Enterprises, Inc.

Lou Klein
8933 Green Chase Drive
Montgomery, AL 36117
941-726-2220

State of Alabama Dept. of Rehab Services

Craig Rogers
3830 Ridgeway Drive
Birmingham, AL 35259
205-414-8430

ARIZONA

Accessible Vans of America

Jerod Redick
3306 E. Washington St. Ste. 201
Phoenix, AZ 85034
417-581-0861

ADA - Adaptive Driving Alliance

Victoria Krull
4218 W. Electra Lane
Glendale, AZ 85310
623-434-0722

Carol Blanc, OTR/L CDRS

5130 E Wagoner Rd.
Scottsdale, AZ 85254
602-239-2905

Driving to Independence LLC

Jennifer Nordine
1414 W. Broadway #218
Tempe, AZ 85282
480-449-3331

Garry's Mobility Service

Garry Green
6 Glen Oaks
Prescott, AZ 86305
928-776-8633

Tempe Mobility

Bill Campbell
7975 S. Autoplex Loop
Tempe, AZ 85284
800-525-7142

CALIFORNIA

Abilities Expo

Valerie Teague
2601 Ocean Park Blvd.
Santa Monica, CA 90405
310-902-2908

Access & Mobility Finance, Inc.

Tom Matson
3732 Mt. Diablo Blvd. Ste. 165
Lafayette, CA 94549
925-299-1039

Adaptive Driving Program

Paul Cooper
P.O. Box 641
Montebello, CA 90640
323-855-1502

David Livingston

1717 W. Santa Ana Ave.
Fresno, CA 93705
559-230-2175

Gregory J. Paquin

6437 W. 77th Street
Los Angeles, CA 90045
310-337-1410

Ludlow Law Office

Robert Ludlow
365 Lake Ave.
Santa Cruz, CA 95062
831-475-5592

Mobility Electronics, Inc.

Warren Vinzant
2419 Irma Way
Castro Valley, CA 94546
510-317-1775

Sharp Memorial Hospital - Rehab

Penny M. Anders
1641 Borana St.
San Diego, CA 92111
858-565-2437

Sharp Rehabilitation

Marilyn Sidler, CDRS
2999 Health Center Drive
San Diego, CA 92373
866-268-8711

Transfer Corporation

Michael J. McCarthy
3460 Larga Avenue
Los Angeles, CA 90039
866-268-8711

COLORADO

Craig Hospital

Sarah Davidson
3425 S. Clarkson Street
Englewood, CO 80113
303-789-8218

Mobility and More dba Kyto Inc.

Tom Black
1447 N. Denver Ave.
Loveland, CO 80538
970-461-8400

Specialty Vehicle Consulting

John Kazanchy
347 Red Rock Circle
Penrose, CO 81240
719-372-6137

CONNECTICUT

CT Bureau of Rehab Services

Glendine Henry
25 Sigourney St., 11th Floor
Hartford 06106
860-424-4859

Easter Seals Mobility Center

Harry Gough
158 State St.
Meriden, CT 06450
203-237-7835

Easter Seals Mobility Center

Tricia Coppola-Passariello
158 State Street
Meriden, CT 06450
203-237-7835

DISTRICT OF COLUMBIA

National Rehab Hospital - OT Dept.

Glenn Digman
102 Irving St. NW
Washington, DC 20010
202-877-1531

FLORIDA

Advanced Driver Rehabilitation Inc.

Judi Hamelburg
1031 Ives Dairy Rd. Suite 228
N. Miami Beach, FL 33179
305-770-0747

Disabled Dealer Enterprise, Inc.

Stella Smith
578 Bimini Bay Blvd.
Apollo Beach, FL 33572
888-521-8778

Driver Rehabilitation Services

Dave Krieger
9315 Hunters Park Way
Tampa, FL 33647
800-738-9967

Lynlo Enterprises, Inc.

Lou Klein
22519 Front Beach Rd. Unit 127
Panama City Beach, FL 32413
941-726-2220

Marie Zuzek

418-8440 Montravail Circle
Tampa, FL 33637
813-600-0615

Pete Galletta

7862 Sailboat Key Blvd. S.
Pinellas Park, FL 33781
727-367-9216

Phillip Faas

4425 63rd Circle
Pinellas Park, FL 33781
727-521-2831

RADCO - FL

William Roeling
5456-A West Crenshaw St.
Tampa, FL 33634
813-243-0370

Rehabilitation Engineering & Technology Program

Stephen Sundarrao
4202 E. Fowler Ave ENB 118
Tampa, FL 33620
813-974-5346

Total Mobility and Modifications Services Inc.

James Z. (Zack) Craft
719 Progress Way
Sanford, FL 32771
407-574-6429

GEORGIA

Georgia Dept. of Labor - Voc Rehab Services

Rajesh Pagadala
1700 Century Circle Ste. 300
Atlanta, GA 30345
478-751-6272

Shepherd Center

Matt Abisamra
2020 Peachtree Rd. NW
Atlanta, GA 30309
404-350-7722

Shepherd Center

Michele Luther-Krug
2020 Peachtree Rd. NW
Atlanta, GA 30309
404-350-7798

Shepherd Center

John Anschutz
2020 Peachtree Rd. NW
Atlanta, GA 30309
404-350-7720

Shepherd Center

James Kennedy
2020 Peachtree Rd. NW
Atlanta, GA 30309
404-367-1296

IOWA

Shivvers Mfg. Inc.

Carl Shivvers
614 W. English
Corydon, IA 50060
641-872-1005

ILLINOIS

Marianjoy Rehab Hospital

Anne Hegberg
26 W. 171 Roosevelt Road
Wheaton, IL 60187
630-909-6080

Marianjoy Rehab Hospital

Danielle Czajkowski
26 W. 171 Roosevelt Road
Wheaton, IL 60187
630-909-6084

Sally Sullivan

907 West Ave.
Woodstock, IL 60098
815-338-7341

Thomas E. Cusack

6476 Sioux Trail
Indian Head Park, IL 60525
708-246-3022

INDIANA

Adapted Mobility Services

Mary Ellen Keith
18 Wilson Drive
Carmel, IN 46032
317-660-6506

NMEDA ASSOCIATE MEMBERS

Adaptive Mobility Services

Carmen Palanca
1156 Ridgeview Ct.
Avon, IN 46123
317-660-6506

Bennett Boehning & Clary LLP

Stuart R. Gutwein
415 Columbia St. Ste. 1000
Lafayette, IN 47901
765-742-9066

Columbus Regional Hospital

Kathy Kachanoski
1732 Timbercrest Dr.
Columbus, IN 47203
800-841-4938 ext. 5902

Easter Seals Crossroads

Mary Follman
4740 Kingsway Drive
Indianapolis, IN 46205
317-466-1000 ext. 2539

Easter Seals Crossroads

Susan Hardesty-Pritchard
4740 Kingsway Drive
Indianapolis, IN 46205
317-721-8636

Indiana Vac-Form. Inc.

Don Robinson
2030 N. Boeing Road
Warsaw, IN 46582
574-269-1725

Margaret Mary Comm. Hospital

Nancy Wylie
8245 Hartford Pike
Aurora, IN 47001
812-926-4484

Memorial Hosp Outpatient Therapy

Carin Mitchell
111 W. Jefferson Street
South Bend, IN 46601
574-647-2600

Memorial Hospital of Southbend

Susan Henderson, CDRS
111 W. Jefferson Street
South Bend, IN 46601
574-647-2600

Regional Rehab Driving, Inc.

Mary Alice Grugel
630 Kathleen Drive
Scherverville, IN 46375
219-718-2366

Rehab. Hospital of Indiana

Laura Trexler
9531 Valparaiso Court
Indianapolis, IN 46268
317-879-8940

The Rehabilitation Center

Jessica Schultheis
3701 Bellemeade Avenue
Evansville, IN 47714
812-479-1411

Therapeutic Mobility Services

Eva Richardville
P.O. Box 8978
Ft. Wayne, IN 46898
260-417-8399

KENTUCKY

Dept. of Vocational Rehab

Kathie Regan
107 Morgan Drive
Nicholasville, KY 40356
859-246-2117

Drivabilities

Brian A. Iadanola, OTR/L, CDRS
3937 Central Avenue
Louisville, KY 40218
502-893-0050

Frazier Rehab Institute

Suzanne Farnan-Maddux
3430 Newburg Road Suite 111A
Louisville, KY 40218
502-451-6886

Heath and Associates

Rick Heath
3316 Springcrest Dr.
Louisville, KY 40241
502-425-2385

Media Venue, Inc.

Weaks McKinney-Smith
10531 Timberwood Cr. Ste. E
Louisville, KY 40223
502-429-6650 x23

On the Road, Again

MaryFrances Gross
4805 Hemlock Way
Lexington, KY 40514
619-607-1142

UK Driving Program

Catherine Greene OTR/L, CDRS
1165 Narrow Lane
Lexington, KY 40517-3048
859-797-6889

University of KY Medical Center

Stacey Stevens
240 Hillsboro Avenue
Lexington, KY 40511
859-255-2555

LOUISIANA

Center for Rehabilitation Engineering (CREST)

Janice Girouard
711 South Vienna Street
Ruston, LA 71270-5845
318-257-4562

Dynamic Care HME (SJC Svcs.)

Steven Courville
4551 Johnson Street
Lafayette, LA 70503
337-984-0123

Louisiana Tech

Michael Shipp
711 S. Vienna
Ruston, LA 71270
318-257-4562

Louisiana Tech University

Marvin King
711 South Vienna
Ruston, LA 71270
318-257-4562

MASSACHUSETTS

Adaptive Driving Program, Inc.

Tricia/Mark Whitehouse
250 Milton St., #LL002
Dedham, MA 02026
781-329-6656

MA Rehab Commission

Eugene Blumkin
27 Wormwood St. Suite 600
Boston, MA 02210
617-204-3721

Royale Mobility LLC

Paul Lastoff
100 Newark Street
Haverville, MA 01832
617-549-3583

MICHIGAN

AM Wins of Michigan, Inc

David Leark
2851 Charlevoix Drive Suite 120
Grand Rapids, MI 49546
616-942-8000

Auto Park Ford

Dan McDonough
1820 S Centerville Rd.
Sturgis, MI 49091
269-651-7728

Fortress Partners

Dave Young
5500 Northland Drive Suite K
Grand Rapids, MI 49525
616-447-2293

Ingenium Engineering Services

George Hicks
4345 Teal Road
Petersburg, MI 48270
734-279-9345

Mark Berk

28911 Seven Mile Rd.
Livonia, MI 48152
734-422-3000

Mary Free Bed Hospital

Greg Brunette
235 Wealthy SE
Grand Rapids, MI 49503
616-456-4857

The Space Between

Kerry Jones
26875 Church St.
Edwardsburg, MI 49112
269-663-0226

University of Michigan Transportation Research Inst.

Larry Schneider
2901 Baxter Road
Ann Arbor, MI 48109
734-936-1103

MINNESOTA

Brandl Auto Connection

Sherri Johnson
559 Hwy 10 South
St. Cloud, MN 56304
763-412-2591

MISSISSIPPI

T.K. Martin Center for Technology and Disability

Dan Allison, MS OTR/L
326 Hardy Rd. Box 9736
Mississippi State, MS 39762
662-325-0886

NORTH CAROLINA

Driver Rehabilitation Services

Cyndee Crompton
605 Cabaret Rd.
McLeansville, NC 27301
336-697-7841

Mike Edwards

3533 Windson Dr.
Charlotte, NC 28209
704-342-6003

NC Division Voc Rehab Scc

Philip Protz
2801 Mail Service Center
Raleigh, NC 27699-2801
919-855-3567

Specialty Transportation Systems

Dexter Warren
2720 North Main Street
Newton, NC 28658
828-464-9738

Triad Mobility Consultants

Steve Reagan
1202 H East Mountain St.
Kernersville, NC 27284
336-992-6122

NEW JERSEY

St. Joseph's Wayne Hospital

Jeanne Schmieder OT, DRS
224 Hamburg Turnpike
Wayne, NJ 07470
973-956-3360

NEW MEXICO

Affordable Mobility -

Auto Electric

Elizabeth Holmes
2035 Corbett Dr.
Las Cruces, NM 88001
505-521-1006

NEW YORK

Agor Acceleration, LLC

Lindsay Agor
205 Maryview Dr.
Webster, NY 14580
585-330-1526

Driver Rehabilitation of the Hudson Valley

MaryBeth Meyer
7 Pine Woods Road
Hyde Park, NY 12538
845-229-2626

Dutchess School of Driving
 Maria Dominijann
 653 Rt 82
 Hopewell Junction, NY 12533
 845-226-6700

Gary R. Hanssen
 224 Doris Ave.
 Vestal, NY 13850
 607-748-8747

Geneva General Hospital
 John Lorenzetti, OTR/L
 196 North Street
 Geneva, NY 14456
 315-787-5444

Paradigm Solutions
 Brian McLane
 29 Rockefeller Blvd.
 Rensselaer, NY 12144
 518-426-8850

Rehab Technology Assoc., Inc.
 Gail Babirad
 PO Box 540
 Kinderhook, NY 12106
 800-987-2753

Rehab Technology Assoc., Inc.
 Jurgen Babirad
 PO Box 540
 Kinderhook, NY 12106
 800-987-2753

Rochester Rehab Center
 Pam Gabryel
 1000 Elmwood Avenue
 Rochester, NY 14620
 585-271-2520

See and Be Safe
c/o Marketing Action Xecutives
 Karen Korman
 50 West 96th Street, Suite 7B
 New York, NY 10025
 212-971-9157

OHIO

Burhill Financial Services
 Amy Brooks
 137 N. Main Street Suite 410
 Dayton, OH 45402
 937-224-3033

**Northwestern Ohio
 Driver Training School**
 Paula Sanford
 101 S. Defiance St. Box 26
 Stryker, OH 43557
 419-682-4741

Ohio Rehab Svcs Commission
 Linda McQuiston
 Rehab Tech Support Unit
 816 - 30th St. NW
 Canton, OH 44709
 330-438-0500

Sea, Ltd.
 Douglas Morr
 7349 Worthington - Galena Rd.
 Columbus, OH 43085
 614-888-4160

Thor Industries
 David Mihalick
 419 W. Pike St.
 Jackson Center, OH 45334
 937-596-6111 ext. 7363

PENNSYLVANIA

Altamera Ltd.
 Joseph Kramer
 2400 Oxford Drive, Suite 210
 Bethel Park, PA 15102
 412-513-5029

Milton S. Hershey Medical Center
 Lori Benner
 MC H-125, P.O. Box 850
 Hershey, PA 17033
 717-531-7444

Moss Rehab Driving Program
 Dan Basore
 201 Old York Road, Suite 203
 Jenkintown, PA 19046
 215-886-7706

**Penn State Milton S.
 Hershey Medical Center**
 Rick Shaffer
 500 University Drive, H125
 Hershey, PA 17033
 717-531-7414

Serge Minassian
 1275 Eagle Rd.
 New Hope, PA 18938
 215-598-3944

Transportation Solutions
 Amy Brzuz
 4202 Peach Street
 Erie, PA 16509
 814-833-2301

SOUTH CAROLINA

**South Carolina Voc Rehab
 Technology Program**
 Tom Jackman
 1410-C Boston Ave.
 W. Columbia, SC 29170
 803-896-6080

TENNESSEE

Dept of Veterans Affairs
 Rhonda Shipman
 1700 Jimmy Malone Road
 Liberty, TN 37095
 682-518-9329

TEXAS

Driving Solutions for Disabilities
 Benjamin Mundy
 5150 Broadway #604
 San Antonio, TX 78205
 210-347-5006

Jordan Ford Mobility
 Ty Beck
 13010 IH 35 North
 San Antonio, TX 78233
 830-386-0446

Mobility Store & More
 James E. Glenewinkel
 1116 E. Kingsbury Street
 Seguin, TX 78155
 830-386-0446

Mobility Unlimited
 Lara Niemann
 P.O. Box 4534
 Odessa, TX 79760
 432-570-5079

Preferred Home Medical
 Loree Rowan
 805 N. Glenwood
 Tyler, TX 75702
 903-597-5656

**Ron Carter MV-1 of
 South Houston**
 Ray Hewitt
 3005 FM 528
 Alvin, TX 77511
 281-388-8507

Strowmatt Rehabilitation Svcs
 Jason Strowmatt, CDRS
 11020 Katy Freeway
 Houston, TX 77043
 713-446-4628

Strowmatt Rehabilitation Svcs
 Chad Strowmatt
 11020 Old Katy Rd. #217
 Houston, TX 77043
 713-722-0667

Texas Transportation Institute
 Eric Bradley
 Texas A&M University
 College Station, TX 77843
 979-845-7492

**TX Transportation Institute
 A&M Univ.**
 Lance Bullard
 3135 TAMU
 College Station, TX 77843
 979-845-6153

VA Medical Center
 Kelly Anderson
 24410 Norchester Way
 Spring, TX 77389
 713-794-7243

VA Prosthetic Dept
 Brad Corkwell
 7400 Merton Minter Blvd.
 San Antonio, TX 78284
 210-617-5144

Vehicle Protection Services
 Lou Dienhart
 3008 Pepper Grass Trail
 Cedar Park, TX 78613
 512-585-5911

VIRGINIA

A Metropolitan Driving School
 John H. Vaughter
 827 E. Parham Road, Suite 2
 Richmond, VA 23227
 804-329-3298

Hanover Healthcare
 Cynthia Booth
 12100 Sunset Hills Rd. Ste. 300
 Reston, VA 20190
 800-831-9506

WASHINGTON

Wheelchair Getaways, Inc.
 Dale Richardson
 P.O. Box 1098
 Mukilteo, WA 98275-1098
 425-353-6563

WISCONSIN

Adaptive Driving Specialists
 Paul Schmidt, OTR/CDRS
 4737 N. Elkhart Ave.
 Whitefish Bay, WI 53211
 414-721-8636

I.S.P. Associates
 Dick Parkin
 150 Dale Dr.
 Oregon, WI 53575
 608-835-0015

**Stout Vocational Rehab
 Institute**
 James Gensch
 221 10th Avenue
 Menomonie, WI 54751
 715-232-2150

CANADA

BRITISH COLUMBIA

FIT Consultants

Dianna Robertson
3405 W 31st Avenue
Vancouver, BC V6S 1X6
Canada
604-263-5286

Larry Bowen Driver Rehab

Larry Bowen
1029 Spruce Avenue
Port Coquitlam, BC V3B 4X5
Canada
604-996-4893 cell

Vancouver Coastal Health

Dean Robertson
4255 Laurel Street
Vancouver, BC V5Z 2G9
Canada
604-734-1313

NEW BRUNSWICK

Stan Cassidy Centre for Rehabilitation

Carol Morrison
800 Priestman
St. Fredericton, BC E3B 0C7
Canada
506-452-5876

ONTARIO

Angela Prosdocimo

335 Caribou Cres.
Thunder Bay, ON P7C 5Z6
Canada
807-343-2431 ext. 2676

F. Lortie

68 Bloomfield
London, ON N6G 1P3
Canada
519-495-9541

Grande National Leasing Inc.

Peter Grande
14 Connie Cres. Unit #6
Concord, ON L4K 2W8
Canada
905-738-3800

J.A. Allen & Associates

Joe Allen
2997 Siverthorn Drive
Oakville, ON L6L 5N4
Canada
603-552-0952

Medichair Ltd.

Harry Hignett
72 Six Point Road
Etobicoke, ON M8Z 2V8
Canada
416-233-3595

MV-1 Canada

Nick Grande
14 Connie Crescent #6
Concord, ON L4K 2W8
Canada
905-738-3800

Parkwood Hospital c/o Driving Assessment & Rehab

Monique MacDonald
801 Commissioners Road
London, ON N6C 5J1
Canada
|416-233-3595

Transport Canada - Road Safety & Motor Vehicle Registration

Harry Baergen
330 Sparks St.
Ottawa, ON K1A 0N5
Canada
613-998-2320

QUEBEC

Centre de Readaptation en Deficience Physique

Guylaine Mercier
253 Route 108
Beauceville, QC G5X 2Z3
Canada
418-774-3410

Centre De readaptation Estrie

Marie-Eve Langlais
300 rue King Est. Bureau 200
Sherbrooke, QC J1G 1B1
Canada
819-346-8411 ext. 43158

Constance Lethbridge Rehabilitation Center

Dana Benoit
7005 boul. de Maisonneuve
West
Montreal, QC H4B 1T3
Canada
514-487-1891 ext. 377

Constance-Lethbridge Rehabilitation Centre

Minh-Thy Truong
7005 boul. de Maisonneuve
West
Montreal, QC H4B 1T3
Canada
514-487-1770 ext. 322

Constance-Lethbridge Rehabilitation Centre

Alyssa Merilees
7005 boul. De Maisonneuve
West
Montreal, QC H4B 1T3
Canada
514-487-1891 ext. 246

Constance-Lethbridge Rehabilitation Centre

Nathalie Maertens
7005, boul. de Maisonneuve
West
Montreal, QC H4B 1T3
Canada
514-487-1891 ext. 380

CRDP Le Bouclier

Johanne Faucher
225 Du Palais
St-Jerome, QC J7Z 1X7
Canada
450-560-9898 ext. 327

Hopital juif de readaptation

Stephanie Laurin
3205 Place Alton - Goldbloom
Laval, QC H7V 1R2
Canada
450-688-9550

Ministere des transports du Quebec

Mohamadou Sissoko
700, boulevard Rene-Levesque
est, 25 etaye
Quebec, QC G1R 5H1
Canada
418-644-9140

Programme Adaptation Vehicule (SAAQ)

Pierre Beaulieu
333 boul Jean-Lesage E-M-27
Quebec City, QC G1K 8J6
Canada
418-528-3310

S.A.A.Q

Frederic Brunet
333 boul Jean-Lesage
Quebec City, QC G1K 8J6
Canada
418-528-4523

S.A.A.Q

Michel Morency
333 boul. Jean-Lesage
Quebec City, QC G1K 8J6
Canada
418-528-3597

SRD Bolduc, Inc.

Jacques Bolduc
32 Duquet
Ste-Therese, QC J7E 3B4
Canada
813-410-4884

INTERNATIONAL

AUSTRALIA

Automobility

Jeff Watters
Unit 3/36 Canterbury Road
Montrose, Vic 3765
Australia
03-9762-2277



- QAP Dealer Member \$0 to \$999,999 in gross sales \$1,050*
- QAP Dealer Member \$1 million to \$2,999,999 in gross sales \$1,575*
- QAP Dealer Member \$3 million and over in gross sales \$2,100*
- QAP Inspection Fee (Initial Inspection) \$600
- Associate Member (Previously Professional Member) \$52.50
- Manufacturer Member \$0 to \$999,999 in gross sales \$1,050
- Manufacturer Member \$1 million to \$2,999,999 in gross sales \$1,575
- Manufacturer Member \$3 million and over in gross sales \$2,100
- Additional Circuit Breaker (Annual) Subscription \$16.50 (per subscription)
Dealer, Associate, and Manufacturer Members receive (ONE) Subscription with membership

* See <http://www.nmeda.com/join-nmeda/> for complete QAP Dealer application process.

CONTACT INFORMATION

Company Name: _____

Type of Business: _____

(Example: Manufacturer, Supplier of Equipment, Conversion Dealer, etc.)

Representative's Name and Title: _____

Street Address: _____

City, State, Zip: _____

Mailing Address (if different from above): _____

Telephone #: _____ Fax #: _____

Tech Name: _____ E-mail Address: _____ Telephone #: _____

Website Address: _____

Permission to link from the NMEDA website to your website: Yes or No (circle one)

E-mail Address: _____

Principal(s): _____

Upon joining NMEDA, we agree to follow the association's Guidelines, Bylaws and Mediation Committee decisions.

Signature: _____

Send payment and information to:

NMEDA
3327 W. Bearss Ave.
Tampa, FL 33618

PH 800-833-0427
FAX: 813 962-8970

www.nmeda.com

CARD TOTAL: \$ _____ EXP. DATE _____ V-CODE: _____

CARD TYPE: (circle one) VISA MASTER CARD AMEX

CARD # _____

CARDHOLDER NAME (PRINT) _____

SIGNATURE _____

Dues payments are not deductible as charitable contributions for federal income tax purposes.
For check payment make check payable to NMEDA.



ADVERTISING INSERTION ORDER

ADVERTISER INFORMATION BILL ME

Company Name <input style="width: 80%;" type="text"/>		Contact <input style="width: 80%;" type="text"/>	
Address <input style="width: 60%;" type="text"/>	City <input style="width: 20%;" type="text"/>	State <input style="width: 10%;" type="text"/>	Zip Code <input style="width: 10%;" type="text"/>
Phone <input style="width: 20%;" type="text"/>	Fax <input style="width: 20%;" type="text"/>	Email <input style="width: 60%;" type="text"/>	

ADVERTISING AGENCY INFORMATION (OPTIONAL) BILL ME

Agency Name <input style="width: 80%;" type="text"/>		Contact <input style="width: 80%;" type="text"/>	
Address <input style="width: 60%;" type="text"/>	City <input style="width: 20%;" type="text"/>	State <input style="width: 10%;" type="text"/>	Zip Code <input style="width: 10%;" type="text"/>
Phone <input style="width: 20%;" type="text"/>	Fax <input style="width: 20%;" type="text"/>	Email <input style="width: 60%;" type="text"/>	

- We authorize advertising insertion(s) in the NMEDA *Circuit Breaker* in the following issue(s):**
- | | | |
|--------------------------------------|--------------------------------------|--------------------------------------|
| <input type="checkbox"/> Winter 2011 | <input type="checkbox"/> Autumn 2012 | <input type="checkbox"/> Summer 2013 |
| <input type="checkbox"/> Spring 2012 | <input type="checkbox"/> Winter 2012 | <input type="checkbox"/> Autumn 2013 |
| <input type="checkbox"/> Summer 2012 | <input type="checkbox"/> Spring 2013 | <input type="checkbox"/> Winter 2013 |

- Our advertisement(s) will be:** *(Rates are per year, 4 issues. Published below at NMEDA member cost.)*
- | | |
|---|---|
| <input type="checkbox"/> Back Cover color \$4042 | <input type="checkbox"/> Half Page b&w \$970 color \$1224 |
| <input type="checkbox"/> Center Spread color \$3638 | <input type="checkbox"/> 1/4 Page b&w \$525 color \$664 |
| <input type="checkbox"/> Inside Cover color \$3234 | <input type="checkbox"/> 1/8 Page b&w \$284 color \$360 |
| <input type="checkbox"/> Full Page b&w \$1779 color \$2830 | <input type="checkbox"/> Business Card Classified b&w \$97 |

Advertisement is: New or Not Changing Changing Periodically **How often?** each issue will notify

BILLING INSTRUCTIONS

ANNUAL RATE: (See Advertising Rates) \$ <input style="width: 150px;" type="text"/>	<input type="checkbox"/> Billed Annually	<input type="checkbox"/> Billed Quarterly
Authorized by: <input type="checkbox"/> Advertiser <input type="checkbox"/> Ad Agency		
Print Name <input style="width: 350px;" type="text"/>	Title <input style="width: 150px;" type="text"/>	
Signature <input style="width: 350px;" type="text"/>	Date <input style="width: 100px;" type="text"/>	

RETURN TO:
Circuit Breaker c/o NMEDA (The National Mobility Equipment Dealers Association)
 3327 West Bearss Avenue, Tampa, Florida 33618
 PHONE: 800.833.0427 • FAX: 813.962.8970 • E-MAIL: info@nmeda.org • URL: www.nmeda.com

DATES TO REMEMBER >>>

This calendar of upcoming events is provided as a service to NMEDA members. The **Circuit Breaker** cannot guarantee the accuracy of the information provided. Please verify dates and locations with the organizations listed.

2012 ADED Conference

July 29 - 31 2012 (Kansas City, Missouri)
Sheraton Kansas City Hotel at Crown Center
Visit www.driver-ed.org for more information.

Abilities Expo - Houston

August 3 - 5, 2012 (Houston, Texas)
Reliant Center
Visit www.abilitiesexpo.com/houston/ for more information.

National Convention for Disabled American Veterans (DAV)

August 4 - 7, 2012 (Las Vegas, Nevada)
Bally's Las Vegas Hotel and Casino
Visit www.dav.org for more information.

Closing the Gap - 30th Annual Conference

October 17 - 19, 2012 (Minneapolis, Minnesota)
DoubleTree by Hilton Hotel Bloomington
Visit www.closingthegap.com for more information.

2012 SEMA Show

October 30 - November 2, 2012 (Las Vegas, Nevada)
Las Vegas Convention Center
Visit www.semashow.com for more information.

2013 ATIA Conference

January 29 - February 2, 2012 (Orlando, Florida)
Caribe Royale All-Suites Resort & Convention Center
Visit www.atia.org for more information.

22nd Annual NMEDA Conference

February 6 - 8, 2013 (Daytona Beach, Florida)
Hilton Oceanfront Resort and Ocean Center
Visit www.nmeda.com for more information.

SAE 2013 World Congress & Exhibition

April 16 - 18, 2013 (Detroit, Michigan)
Cobo Center
Visit www.sae.org/congress/ for more information.



To have your information included in *Dates to Remember*, mail or fax it at least 12 weeks before the event to info@nmeda.org or fax (813) 962-8970.

FREE.

It's the most powerful word in the English language.

And now we're putting it to work for
NMEDA DEALERS.

Free Advertising Materials

NMEDA has created a free online library of print ads and radio commercials available for your use. The print ads are in both color and black and white, English and French and available in various sizes to be used for magazines and newspapers. The radio spots are available in :30 to :60 second lengths catered to different audiences.

Each item can be customized with your personalized dealer and address information. Simply download the files for your graphics department to work with or you have the option to preview the files as a PDF. Please note you will need InDesign Creative Suite 4 or higher to work with the print ad files. To see the complete library of available work visit the **Cooperative Awareness Program** section under **Member Login** at www.nmeda.com.



Free Research

In the second quarter of 2010, NMEDA commissioned a study to help understand the competitive marketplace for our association, measure awareness of NMEDA and the services provided. This information helps determine where opportunity exists regarding attitudes, influences and lifestyle factors that affect the decision to purchase a vehicle modification. A secondary research study was conducted targeting Physical Therapists, Occupational Therapists and caregivers to determine where opportunity exists in key attitudes, decision criteria and influencing. To download the research studies visit the **Cooperative Awareness Program** section under **Member Login** at www.nmeda.com.

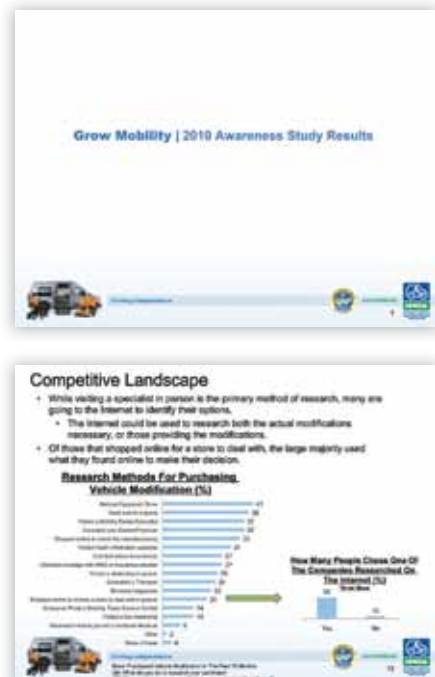

NMEDA members now have access to free advertising and marketing materials that are designed to promote the network of NMEDA dealers, help expand your customer base and increase sales of mobility products. The online library enables dealers and QAP dealers to personalize free advertising to run in their market, creating a customizable solution to your specific advertising needs - just like the invaluable, personalized services you provide your clients.

Driving Independence

Free Services

If you need help putting your logo, address or dealer info on any of the print ad files, just let us know. We'll be happy to do it for you free if you have a hi-res logo. Radio spots are available in several versions and all have time available at the end of each spot so they can be tagged with your name and location information. Most radio stations will tag your location for free with the purchase of the media. To find out more visit the **Cooperative Awareness Program** section under **Member Login** at www.nmeda.com.

Take advantage and utilize the dealer brochure to help explain the benefits of working with a NMEDA dealer.

Free Website Templates

If you do not have a website, choose from one of the available templates. All you need to do is to provide your logo, company information, images and content and we can help you build it out and customize it for free. To find out more information visit the **Cooperative Awareness Program** section under **Member Login** at www.nmeda.com.



All marketing and advertising materials are fully customizable for your business and local markets. Save time and money by taking advantage of these free items now.

NMEDA.com 866.948.8341



THE LAST WORD

New Online Resource Available FREE for NMEDA Members!

By Pete Lucas

In response to Dealer member requests we have put together a free online resource for you, the Make Inoperative Module (MIM). This 20-minute online course will help you better understand NHTSA Make Inoperative Exemption regulations and paperwork requirements. Kristen Clevidence, QAP Coordinator at NMEDA, narrates this course and shows you specific examples from the following topics:

- How to register with NHTSA to use the Make Inoperative Exemption
- Common issues, questions, and non-exempt items
- How to properly use the Make Inoperative Forms and Labels & find documents

To view the Make Inoperative Module, contact Pete Lucas by email at pete@nmeda.org. Ask for the direct link to the course.

More FREE Online Resources for NMEDA Members (Certificate or Audit Available)

NMEDA also provides QAP 1-2-3 courses free to all Dealer members upon request. An official 2-year hard copy certificate is available for QAP-3 Guidelines Training as a stand-alone unit or for QAP 1-2-3 as a bundled course. This online course is accredited by ADED and available for 3 contact hours.

Please specify if you want to take the courses for credit (certificate) or audit only. For-credit courses with certificates require that you set up a free Ignitecast account and successfully pass cumulative quizzes through out the training (75% or higher).

Here's a summary of each below:

- **QAP 1:** Introduction to NMEDA QAP. Briefly explains many benefits and gives details on the quick 6 step enrollment process.
- **QAP 2:** Audit Preparation- What best practices are inspected for at QAP participating NMEDA member Dealers. A step-by-step guide through the Quality Control Manual, pre-inspection preparation, and postinspection accreditation.
- **QAP 3:** Guidelines Training - Review of entire NMEDA Guidelines best practices. 2.75% min.cum.score for 2-year certificate

QAP 1-2-3: Bundled course containing QAP 1-2-3 above. 75% minimum cumulative score for 2-year certificate.



340th Anniversary



Forty years ago The Braun Corporation was formed to open the door to mobility and freedom. Since then we've changed hundreds of thousands of lives and helped redefine independence for individuals with disabilities.



Ralph W. Braun

We're very honored to celebrate our 40th anniversary this year with you, our BraunAbility dealers. It's been an incredibly rewarding journey so far, and all of us are excited about what the future holds.

We owe our success to you!



www.BraunAbility.comTM